

D

C

B

A

4

4

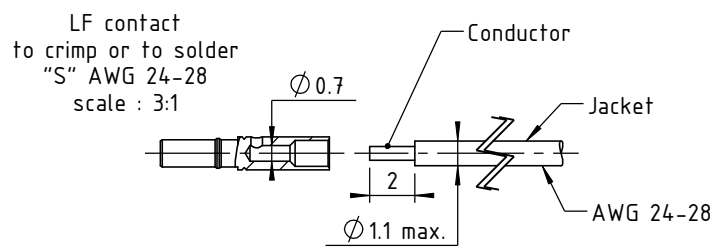
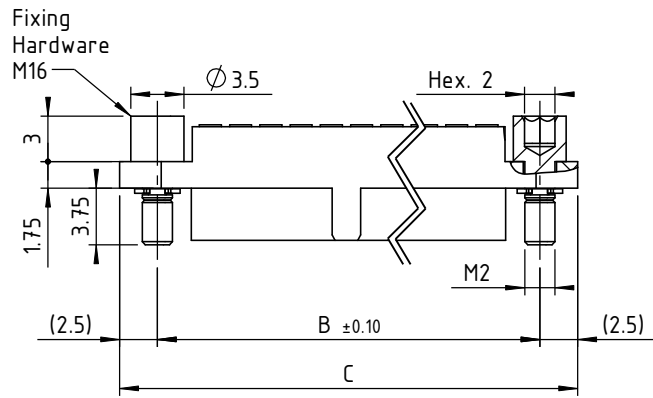
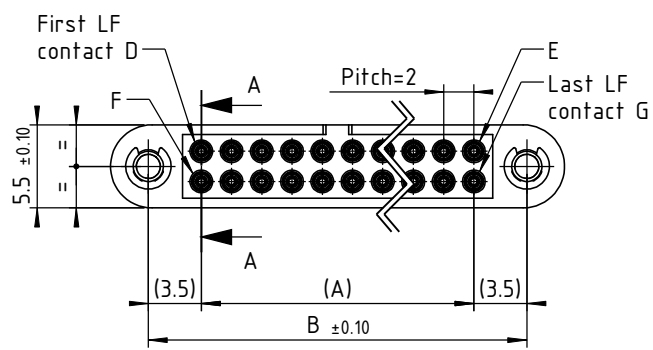
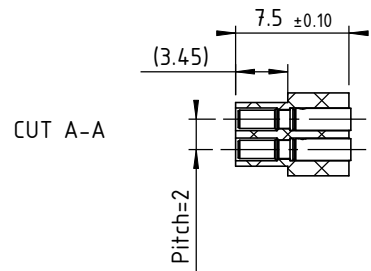

TECHNICALS FEATURES

MATERIAL

INSULATOR : Special PPS (Polyphenylene Sulfide Fiberglass filled thermoplastic) UL 94-V0

- Radiation resistance
- No humidity absorption
- Oxygen free

Note : PPS characteristics are recognized for space applications

CRIMPING SIGNAL CONTACTS :

- Female :
- Body : Copper alloy / Ni + Au 0.2µ
 - Socket body : Beryllium copper / Ni + Au 1.25µ

FIXING HARDWARE :

- Jackscrew : Stainless steel

ELECTRICAL for LF Contacts

- All contacts : 3 A max. @ 25°C
2.2 A max. @ 85°C
Tested at 800 V DC
- Working voltage (sea level) : Tested at 1200 V DC
- Proof voltage : max. 10 mΩ
- Contact resistance (initially) : 1000 MΩ min
- Insulation resistance : 3 cycles

MECHANICAL for LF Contacts

- Mechanical operations : 500 cycles min. up to 2500.
- Contact insertion and withdrawal force : 2 N max. / 0.2 N min.
- Contact retention in insulator : 10 N min.
- Contact replacement in insulator : 3 cycles

ENVIRONMENTAL

- Temperature range : From -60°C to +260°C
- Vibration severity : 0.75mm, 10 g RMS 6 hours long random with superimposed sinusoid. No intermittencies measured when using an H.S.L.I. (High Speed Logic Interrupt) detector with a trip threshold of 2 ns.
- Shock severity : 100g for 6 ms
- Solvent resistance : HcFc 141 bMGX (ATOCHEM) solvent
- Salt spray test : 96 hrs
- Humidity test : 56 days @ 90% Humidity

3D view scale : 1.5:1



Crimping following cable instruction ICLF01
Marking as referenced in the CMM catalogue pages 12 & 13

CONNECTOR SERIES 220 FEMALE							
LF contacts number mm	Distance in mm between axes		Length in mm	LF contacts reference mark number			
	A	B		D	E	F	G
04	2	9	14	1	2	3	4
06	4	11	16	1	3	4	6
08	6	13	18	1	4	5	8
10	8	15	20	1	5	6	10
12	10	17	22	1	6	7	12
14	12	19	24	1	7	8	14
16	14	21	26	1	8	9	16
18	16	23	28	1	9	10	18
20	18	25	30	1	10	11	20
22	20	27	32	1	11	12	22
24	22	29	34	1	12	13	24
26	24	31	36	1	13	14	26
28	26	33	38	1	14	15	28
30	28	35	40	1	15	16	30
32	30	37	42	1	16	17	32
34	32	39	44	1	17	18	34
36	34	41	46	1	18	19	36
38	36	43	48	1	19	20	38
40	38	45	50	1	20	21	40
42	40	47	52	1	21	22	42
44	42	49	54	1	22	23	44
46	44	51	56	1	23	24	46
48	46	53	58	1	24	25	48
50	48	55	60	1	25	26	50
52	50	57	62	1	26	27	52
54	52	59	64	1	27	28	54
56	54	61	66	1	28	29	56
58	56	63	68	1	29	30	58
60	58	65	70	1	30	31	60

Tools recommended	
LF contacts insertion & withdrawal tool	P/N C12935
Recommended hand crimp tool	P/N MH800
Recommended positionner K 1692	P/N C12929
AWG24 crimp tool setting	Position 7
AWG26 & AWG28 crimp tool setting	Position 6

nicomatic
www.nicomatic.com
Mail : nicomatic@nicomatic.fr
Tel : +33 (0)4.50.36.13.85

2	06/03/09	H.L.	E.M.	D.Z.
Iss	Date	Drawn	Checked	Approved
Item : Connector CMM 220 female to crimp AWG 24-28, nn LF contacts, M16				

This document and drawings, sketches, and schematic drawings are the property of the NICOMATIC company. and no parts thereof may be reproduced and used without the written consent of the owner. Law dated 11.03.1902

Catalogue Reference : 222SnnM16

	General tolerance ±0.2	Scale 2:1	Page 1/1
--	------------------------	-----------	----------



D

A4