



## 464 Series Fuse



### Agency Approvals

AGENCY	AGENCY FILE NUMBER	AMPERE RANGE
	NBK30502-E108480A	1A - 6.3A
	E184655A,B	500mA - 6.3A

### Electrical Characteristics for Series

% of Ampere Rating	Opening Time
125%	1 hour, Minimum
200%	2 minutes, Maximum
1000%	0.001 sec., Min.; 0.01 sec., Max.

### Description

The Surface Mount Nano<sup>2</sup> 250V UMF product family complies with IEC Publication IEC60127-4-Universal Modular Fuse-Links [UMF]. This IEC standard has been accepted world wide.

### Features

- Fast Acting
- Listed to IEC 60127-4, Universal Modular Fuse-Links (UMF), 250V
- 250VAC Voltage rating
- RoHS compliant and Halogen Free

### Applications

- Power supply
- Lighting system
- White goods
- Industrial equipment
- Medical equipment

### Additional Information



Datasheet





Resources



Samples

### Electrical Specifications by Item

Ampere Rating (A)	Amp Code	Max Voltage Rating (V)	Interrupting Rating	Nominal Cold Resistance (Ohms)	Nominal Melting I <sup>2</sup> t (A <sup>2</sup> sec)	Nominal Voltage Drop (mV)	Agency Approvals	
								
0.500	.500	250	100 amperes @250VAC	0.2373	0.22	600		x
0.800	.800	250		0.1159	0.96	400		x
1.00	001.	250		0.0762	0.51	300	x	x
1.25	1.25	250		0.0580	0.98	300	x	x
1.60	01.6	250		0.0448	1.67	300	x	x
2.00	002.	250		0.0354	2.48	300	x	x
2.50	02.5	250		0.0288	3.99	300	x	x
3.15	3.15	250		0.0206	8.05	300	x	x
4.00	004.	250		0.0156	13.85	300	x	x
5.00	005.	250		0.0119	23.6	300	x	x
6.30	06.3	250		0.0093	53.33	300	x	x

Notes:  
 - I<sup>2</sup>t calculated at 8ms.  
 - Resistance is measured at 10% of rated current, 25°C  
 - For information and availability of additional ratings please contact Littelfuse

## Temperature Derating Curve

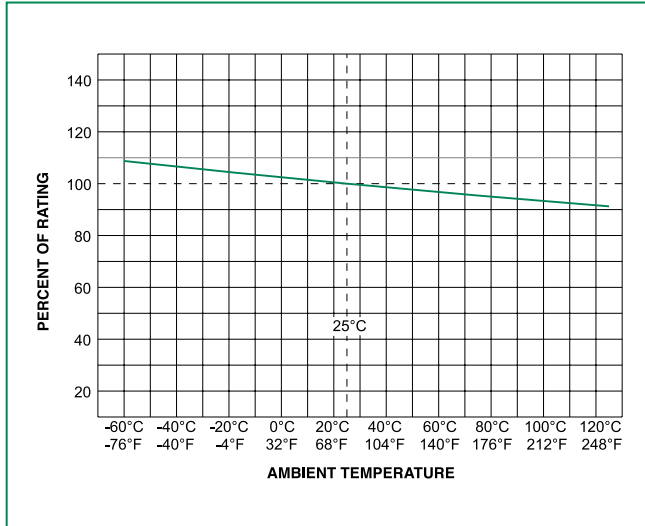

Note:

1. Derating depicted in this curve is in addition to the standard derating of 15% for continuous operation.

## Average Time Current Curves

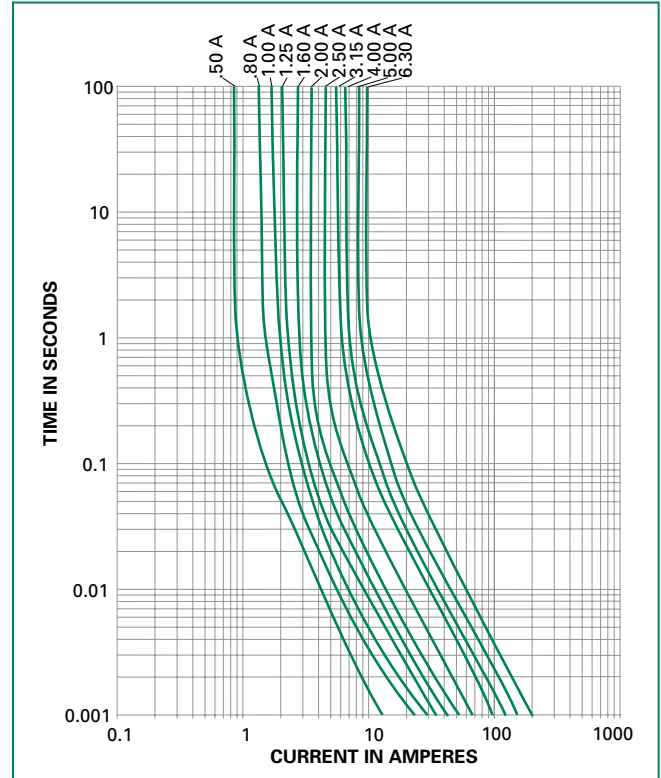

## Soldering Parameters

Reflow Condition		Pb – Free assembly
Pre Heat	- Temperature Min ( $T_{s(min)}$ )	150°C
	- Temperature Max ( $T_{s(max)}$ )	200°C
	- Time (Min to Max) ( $t_s$ )	60 – 120 secs
Average ramp up rate (Liquidus Temp ( $T_L$ ) to peak)		5°C/second max.
$T_{s(max)}$ to $T_L$ - Ramp-up Rate		5°C/second max.
Reflow	- Temperature ( $T_L$ ) (Liquidus)	217°C
	- Temperature ( $t_L$ )	60 – 90 seconds
Peak Temperature ( $T_p$ )		260 <sup>+0/-5</sup> °C
Time within 5°C of actual peak Temperature ( $t_p$ )		20 – 40 seconds
Ramp-down Rate		5°C/second max.
Time 25°C to peak Temperature ( $T_p$ )		8 minutes max.
Do not exceed		260°C
Wave Soldering Parameters		260°C Peak Temperature, 10 seconds max.

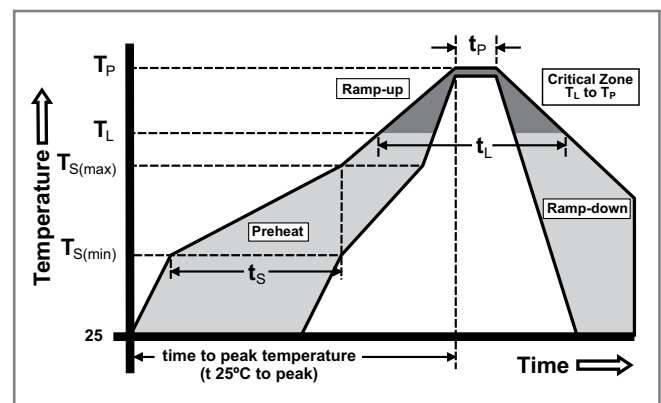

## Product Characteristics

<b>Materials</b>	Body: Ceramic Terminations: Silver-plated Caps
<b>Product Marking</b>	Brand, Ampere Rating, Voltage Rating, UMF Logo
<b>Operating Temperature</b>	-55°C to 125°C
<b>Moisture Sensitivity Level</b>	Level 1, J-STD-020C
<b>Solderability</b>	IEC 60127-4
<b>Insulation Resistance (after Opening)</b>	IEC 60127-4 (0.1Mohm min @ 500VDC)

<b>Thermal Shock</b>	MIL-STD-202, Method 107, Test Condition B, 5 cycles, -65°C / +125°C
<b>Mechanical Shock</b>	MIL-STD-202, Method 213, Test Condition A
<b>Vibration</b>	MIL-STD-202, Method 201 (10-55 Hz)
<b>Moisture Resistance</b>	MIL-STD-202, Method 106, 10 cycles
<b>Salt Spray</b>	MIL-STD-202, Method 101, Test Condition B (48hrs)
<b>Resistance to Soldering Heat</b>	IEC 60127-4

## Dimensions

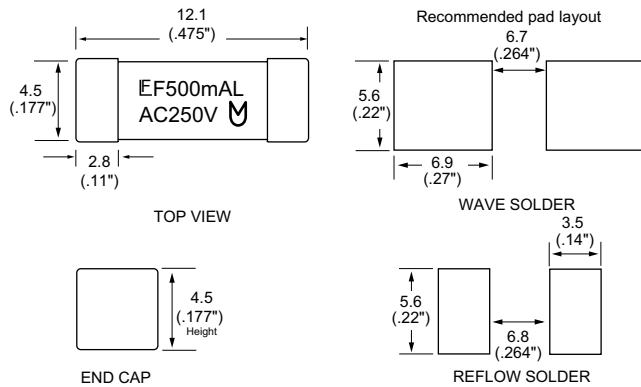

## Part Numbering System

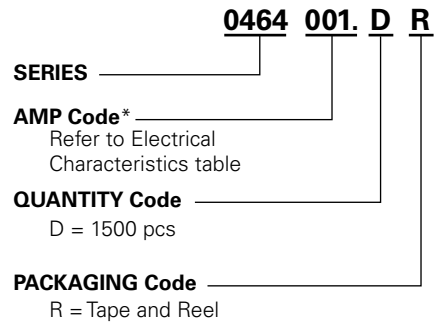

**\*Example:**  
2.5 amp product is 0464**02.5**DR  
(1 amp product shown above).

## Packaging

Packaging Option	Packaging Specification	Quantity	Quantity & Packaging Code
24mm Tape and Reel	EIA RS-481-1 (IEC 286, part 3)	1500	DR