

PAGE 1/3	ISSUE 08-06-15C	SERIES SMP	PART NUMBER R222052000
----------	-----------------	------------	------------------------

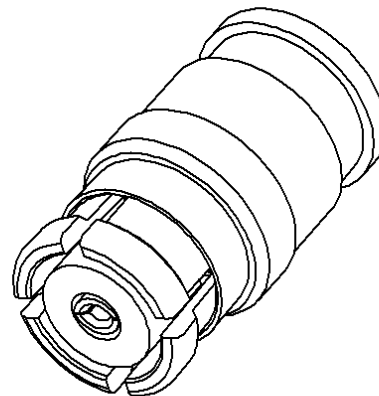

All dimensions are in mm.

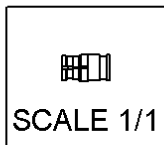
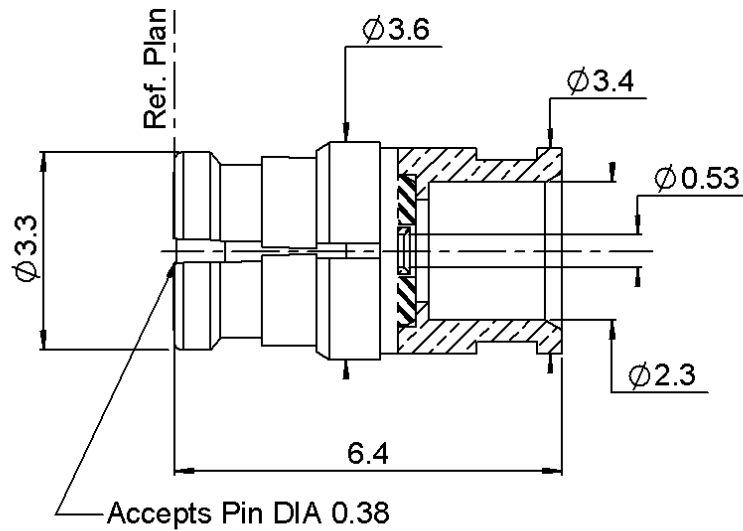

COMPONENTS	MATERIALS	PLATING ( $\mu\text{m}$ )
Body	<b>BERYLLIUM COPPER</b>	<b>GOLD 1.3 OVER NICKEL2</b>
Center contact	<b>BERYLLIUM COPPER</b>	<b>GOLD 1.27 OVER NICKEL 1.27</b>
Outer contact	-	-
Insulator	<b>PTFE</b>	-
Gasket	-	-
Others parts	<b>BERYLLIUM COPPER</b>	<b>GOLD 1.3 OVER NICKEL2</b>
-	-	-
-	-	-

PAGE <b>2/3</b>	ISSUE <b>08-06-15C</b>	SERIES <b>SMP</b>	PART NUMBER <b>R22052000</b>
-----------------	------------------------	-------------------	------------------------------

### PACKAGING

Standard	Unit	Other
<b>100</b>	<b>Contact us</b>	<b>Contact us</b>

### ELECTRICAL CHARACTERISTICS

Impedance	<b>50</b>	$\Omega$
Frequency	<b>0-40</b>	GHz
VSWR	<b>1.35 + 0,0000</b>	x F(GHz) Maxi
Insertion loss	<b>0.12</b>	$\sqrt{F}$ (GHz) dB Maxi
RF leakage	- (	- F(GHz)) dB Maxi
Voltage rating	<b>335</b>	Veff Maxi
Dielectric withstanding voltage	<b>500</b>	Veff mini
Insulation resistance	<b>5000</b>	M $\Omega$ mini

### MECHANICAL CHARACTERISTICS

Center contact retention		
Axial force – Mating End	<b>NA</b>	N mini
Axial force – Opposite end	<b>NA</b>	N mini
Torque	<b>NA</b>	N.cm mini
Recommended torque		
Mating	<b>NA</b>	N.cm
Panel nut	<b>NA</b>	N.cm
Clamp nut	<b>NA</b>	N.cm
A/F clamp nut	<b>0,0000</b>	mm
Mating life	<b>100</b>	Cycles mini
Weight	<b>0,0900</b>	g

### ENVIRONMENTAL

Operating temperature	<b>-65/+165</b>	$^{\circ}\text{C}$
Hermetic seal	<b>NA</b>	Atm.cm3/s
Panel leakage	<b>NA</b>	

### SPECIFICATION

### CABLE ASSEMBLY

Stripping	a	b	c	d	e	f
mm	<b>1,3</b>	<b>0</b>	<b>0</b>	<b>0</b>	<b>0</b>	<b>0</b>

Assembly instruction:

Recommended cable(s)

**KS 1**  
**RG 405**  
**SHF2.4M**

Characteristics indicated on this data sheet are those that can be achieved with the highest performance cable. Intrinsic limitations of the cable may diminish the performance of the assembly

Cable retention

- pull off	<b>200</b>	N mini
- torque	<b>NA</b>	N.cm

### TOOLING

Part Number	Description	Hexagon
R282051000	STRIPPING TOOL	
R282062010	POINTER GAUGE	
R282740030	SOLDERING MOUNTING	
R282743120	POSITIONER FOR SOLDERING SMP	
R282744253	POSITIONER FOR SOLDERING SMP	
R282862050	SOLDER GAUGE THCK .012	

### OTHER CHARACTERISTICS

**RF leakage:-80dB DC-3GHz**  
**-65dB 3-26.5GHz**  
**Compliant with MIL-STD-348**

PAGE 3/3	ISSUE 08-06-15C	SERIES SMP	PART NUMBER R222052000
----------	-----------------	------------	------------------------

**COMPONENTS**

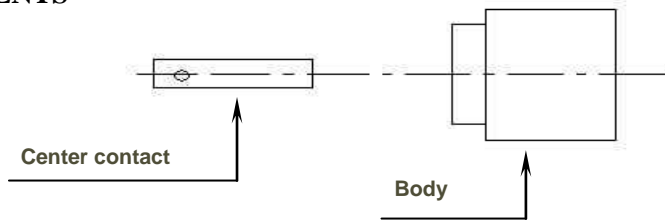

**STRIPPING CABLES**



We recommend a thermal preconditioning cable

**1**

Strip the dielectric of the cable .  
Trim the cable .  
Clean the cable .  
Iron temperature not exceed 250°C

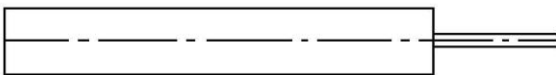

**2**

Screw the positioner onto the soldering jig.  
Slide center contact into positioner.  
Insert solder gauge between contact and cable .  
Tighten and solder the contact.

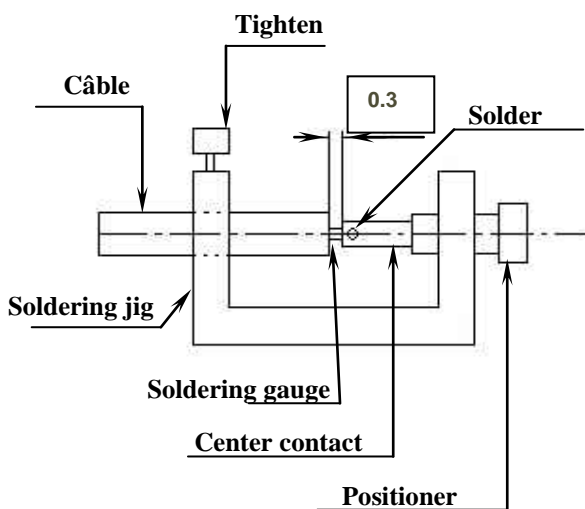

**3**

After cooling remove cable assembly from the jig.  
Slide body into positioner .  
Slide cable into the connector until it bottoms against the positioner .  
Tighten.  
Solder the body onto the cable.  
After cooling remove cable assembly from the jig.

