

TLV1805 40V, Rail-to-Rail Input, Push-Pull Output, High Voltage Comparator with Shutdown

1 Features

- 3.3 V to 40 V Supply Range
- Low Quiescent Current: 135 μ A
- High Peak Current Push-Pull Output
- Rail-to-Rail Inputs with Phase Reversal Protection
- Built-In Hysteresis: 14mV
- 250ns Propagation Delay
- Low Input Offset Voltage: 500 μ V
- Shutdown with High-Z Output
- Power-On Reset (POR)
- SOT-23-6 Package

2 Applications

- Reverse Current Protection Smart Diode Controller
- Overvoltage, Undervoltage, and Overcurrent Detection
- OR-ing MOSFET Controller
- MOSFET Gate Driver
- High Voltage Oscillators
- System Monitoring for:
 - Infotainment & Cluster
 - PLC's
 - Servers
 - Motor Protection & Control

3 Description

The TLV1805 high voltage comparator offers the unique combination of wide supply range, push-pull output, rail-to-rail inputs, low quiescent current, shutdown capability and fast output response. All these features make this comparator well-suited for applications that require sensing at the positive or negative voltage rails such as reverse current protection for a smart diode controller, overcurrent sensing, and overvoltage protection circuits where the push-pull output stage is used to drive the gate of a p-channel or n-channel MOSFET switch.

The high peak current push-pull output stage, which is unique for high-voltage comparators, offers the advantage of allowing the output to actively drive the load to either supply rail with a fast edge rate. This is especially valuable in applications where a MOSFET gate needs to be driven high or low quickly in order to connect or disconnect a host from an unexpected high voltage supply. Additional features such as low input offset voltage, low input bias currents and High-Z shutdown make the TLV1805 flexible enough to handle a broad range of applications. Power-On reset prevents false outputs at power-up.

The TLV1805 is in a 6-pin SOT-23 package and is specified for operation across the extended industrial temperature range of -40°C to $+125^{\circ}\text{C}$.

Device Information⁽¹⁾

PART NUMBER	PACKAGE	BODY SIZE (NOM)
TLV1805	SOT-23 (6)	1.60 mm x 2.90 mm

(1) For all available packages, see the package option addendum at the end of the datasheet.

Overvoltage Protection Using P-Channel MOSFET

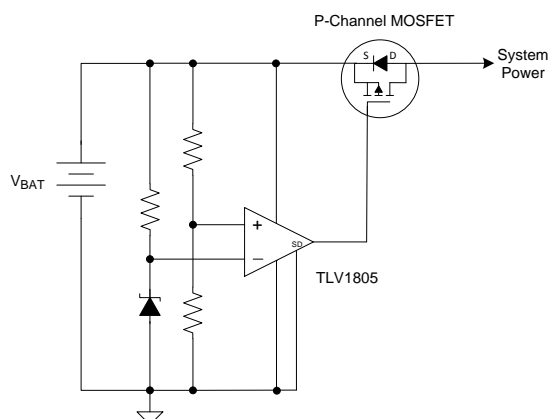

Reverse Current & Overvoltage Protection Using P-Channel MOSFETs

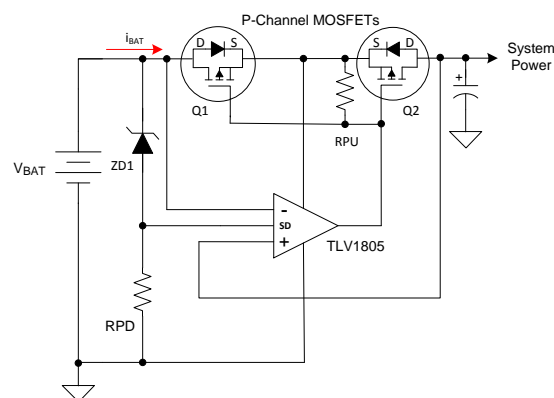

Table of Contents

1 Features	1	7.4 Device Functional Modes.....	18
2 Applications	1	8 Application and Implementation	21
3 Description	1	8.1 Application Information.....	21
4 Revision History	2	8.2 Typical Applications	21
5 Pin Configuration and Functions	3	9 Power Supply Recommendations	28
6 Specifications	4	10 Layout	28
6.1 Absolute Maximum Ratings	4	10.1 Layout Guidelines	28
6.2 ESD Ratings.....	4	10.2 Layout Example	28
6.3 Recommended Operating Conditions.....	4	11 Device and Documentation Support	29
6.4 Thermal Information	4	11.1 Documentation Support	29
6.5 Electrical Characteristics.....	5	11.2 Receiving Notification of Documentation Updates	29
6.6 Switching Characteristics	5	11.3 Community Resources.....	29
6.7 Typical Characteristics	7	11.4 Trademarks	29
7 Detailed Description	17	11.5 Electrostatic Discharge Caution.....	29
7.1 Overview	17	11.6 Glossary	29
7.2 Functional Block Diagram	17	12 Mechanical, Packaging, and Orderable	29
7.3 Feature Description.....	17	Information	29

4 Revision History

NOTE: Page numbers for previous revisions may differ from page numbers in the current version.

DATE	REVISION	NOTES
December 2018	*	Initial APL release.

5 Pin Configuration and Functions

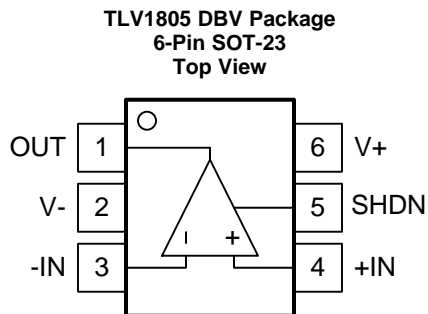

Note the reversed positions of the input pins. This differs from a similar popular pinout.

Pin Functions

PIN		TYPE	DESCRIPTION
NAME	NO.		
IN+	4	I	Noninverting input
IN-	3	I	Inverting input
OUT	1	O	Output
SHDN	5	I	Shutdown (active high)
V+	6	P	Positive (highest) power supply
V-	2	P	Negative (lowest) power supply

6 Specifications

6.1 Absolute Maximum Ratings

 over operating free-air temperature range (unless otherwise noted)⁽¹⁾

	MIN	MAX	UNIT
Supply voltage: $V_S = (V+) - (V-)$	-0.3	42	V
Input pins (IN+, IN-) ⁽²⁾	(V-) - 0.3	(V+) + 0.3	V
Shutdown pin (SHDN) ⁽³⁾	(V-) - 0.3	(V-) + 5.5	V
Current into Input pins (IN+, IN-, SHDN) ⁽²⁾		±10	mA
Output (OUT)	(V-) - 0.3	(V+) + 0.3	V
Operating temperature	-55	150	°C
Junction temperature, T_J		150	°C
Storage temperature, T_{stg}	-65	150	°C

- (1) Stresses beyond those listed under *Absolute Maximum Ratings* may cause permanent damage to the device. These are stress ratings only, which do not imply functional operation of the device at these or any other conditions beyond those indicated under *Recommended Operating Conditions*. Exposure to absolute-maximum-rated conditions for extended periods may affect device reliability.
- (2) Input terminals are diode-clamped to the power-supply rails. Input signals that can swing more than 0.3 V beyond the supply rails must be current-limited to 10 mA or less.
- (3) Shutdown pin is diode-clamped to (V-). Input to SHDN that can swing more than 0.3 V below (V-) must be current-limited to 10 mA or less.

6.2 ESD Ratings

			VALUE	UNIT
$V_{(ESD)}$	Electrostatic discharge	Human-body model (HBM), per ANSI/ESDA/JEDEC JS-001 ⁽¹⁾	±1500	V
		Charged-device model (CDM), per JEDEC specification JESD22-C101 ⁽²⁾	±750	

- (1) JEDEC document JEP155 states that 500-V HBM allows safe manufacturing with a standard ESD control process.
- (2) JEDEC document JEP157 states that 250-V CDM allows safe manufacturing with a standard ESD control process.

6.3 Recommended Operating Conditions

over operating free-air temperature range (unless otherwise noted)

	MIN	MAX	UNIT
Supply voltage: $V_S = (V+) - (V-)$	3.3	40	V
Ambient temperature, T_A	-40	125	°C

6.4 Thermal Information

THERMAL METRIC ⁽¹⁾		TLV1805	UNIT
		DBV (SOT23)	
		6 PINS	
$R_{\theta JA}$	Junction-to-ambient thermal resistance	166.9	°C/W
$R_{\theta JC(top)}$	Junction-to-case (top) thermal resistance	104.2	°C/W
$R_{\theta JB}$	Junction-to-board thermal resistance	46.8	°C/W
Ψ_{JT}	Junction-to-top characterization parameter	31.3	°C/W
Ψ_{JB}	Junction-to-board characterization parameter	46.6	°C/W

- (1) For more information about traditional and new thermal metrics, see the [Semiconductor and IC Package Thermal Metrics](#) application report.

6.5 Electrical Characteristics

$V_S = 3.3\text{ V to }40\text{ V}$, $V_{CM} = V_S / 2$; $T_A = 25^\circ\text{C}$ (unless otherwise noted). Typical values are at $V_S = 12\text{ V}$ and $T_A = 25^\circ\text{C}$, $V_{CM} = V_S / 2$

PARAMETER		TEST CONDITIONS	MIN	TYP	MAX	UNIT
V _{IO}	Input offset voltage	$V_S = 3.3\text{V}, 12\text{V and }40\text{V}$	-4.5	±0.5	4.5	mV
		$V_S = 3.3\text{V}, 12\text{V and }40\text{V}, T_A = -40^\circ\text{C to }+125^\circ\text{C}$	-6.5		6.5	
dV _{IO} /dT	Input offset voltage drift	$T_A = -40^\circ\text{C to }+125^\circ\text{C}$		±2.5		µV/°C
V _{HYS}	Input hysteresis voltage			14		mV
V _{CM}	Common-mode voltage range	$T_A = -40^\circ\text{C to }+125^\circ\text{C}$	(V-) - 0.2		(V+) + 0.2	V
I _B	Input bias current			0.05		pA
I _{OS}	Input offset current			0.05		pA
PSRR	Power-supply rejection ratio	$V_{CM} = V_-$		95		dB
CMRR	Common-mode rejection ratio	$(V_-) < V_{CM} < (V_+)$		80		dB
V _{OL}	Voltage output swing from (V-)	$I_{SINK} \leq 5\text{mA}$, input overdrive = -100 mV, $V_S = 5\text{V}, T_A = -40^\circ\text{C to }+125^\circ\text{C}$			300	mV
V _{OH}	Voltage output swing from (V+)	$I_{SOURCE} \leq 5\text{mA}$, input overdrive = +100 mV, $V_S = 5\text{V}, T_A = -40^\circ\text{C to }+125^\circ\text{C}$			300	mV
I _{sc_source}	Peak charging current (sourcing) with output shorted to V- ⁽¹⁾	$V_S = 5\text{ V to }40\text{ V}$		100		mA
I _{sc_sink}	Peak dis-charging current (sinking) with output shorted to V+ ⁽¹⁾	$V_S = 5\text{ V to }40\text{ V}$		100		mA
I _Q	Quiescent current	$V_S = 12\text{ V}$, no load, $V_{ID} = -0.1\text{ V}$ (output low), $T_A = 25^\circ\text{C}$		135	200	µA
		$V_S = 12\text{V to }40\text{V}$ no load, $V_{ID} = -0.1\text{ V}$ (output low), $T_A = -40^\circ\text{C to }+125^\circ\text{C}$			400	µA
t _{OFF}	Time to enter shutdown	$C_L = 15\text{ pF}$		1.0		µs
t _{ON}	Time to exit shutdown	$C_L = 15\text{ pF}$		2.3		µs
V _{SD}	Shutdown input: voltage range ⁽²⁾	$V_S = 3.3\text{ to }40\text{V}, T_A = -40\text{ to }125^\circ\text{C}$	0		5.5	V
V _{SD_VIH}	SHDN pin input high level	$V_S = 3.3\text{ V and }40\text{V}, T_A = -40\text{ to }125^\circ\text{C}$	2	1.35		V
V _{SD_VIL}	SHDN pin input low level	$V_S = 3.3\text{ V and }40\text{V}, T_A = -40\text{ to }125^\circ\text{C}$		0.65	0.4	V
I _{B-SDH}	SHDN bias current	$V_S = V_{SD} = 5.5\text{ V}$		0.015		nA
		$V_S = 5\text{ V}, V_{SD} = 0\text{ V}$		0.001		nA
I _{Q-SD}	Quiescent current (Shutdown)	$V_S = 12\text{V}; T_S = 25^\circ\text{C}; V_{SD} > V_{SD_VIH\ Min}$		9.5	13	µA

(1) Continuous short circuit can result in excessive heating and exceeding the maximum allowed junction temperature of 150°C. Please refer to the Maximum Output Current Derating curve in the Typical Operation Plots.

(2) The recommended voltage range if V_{SD} is independent of V_S .

6.6 Switching Characteristics

Typical values are at $T_A = 25^\circ\text{C}$, $V_S = 12\text{ V}$, $V_{CM} = V_S / 2$; Input overdrive = 100 mV (unless otherwise noted).

PARAMETER		TEST CONDITIONS	MIN	TYP	MAX	UNIT
t _{PHL}	Propagation delay time, high-to-low ⁽¹⁾	$C_L = 15\text{ pF}$		250		ns
		$C_L = 4\text{ nF}$		450		ns
t _{PLH}	Propagation delay time, low-to-high ⁽¹⁾	$C_L = 15\text{ pF}$		250		ns
		$C_L = 4\text{ nF}$		500		ns
t _R	Rise time	20% to 80%, $C_L = 15\text{ pF}$		18		ns
		20% to 80%, $C_L = 4\text{ nF}$		0.3		µs
t _F	Fall time	20% to 80%, $C_L = 15\text{ pF}$		10		ns
		20% to 80%, $C_L = 4\text{ nF}$		0.26		µs

(1) High-to-low and low-to-high refers to the transition at the input.

Switching Characteristics (continued)

Typical values are at $T_A = 25^\circ\text{C}$, $V_S = 12\text{ V}$, $V_{CM} = V_S / 2$; Input overdrive = 100 mV (unless otherwise noted).

PARAMETER	TEST CONDITIONS	MIN	TYP	MAX	UNIT
t_{START}	Power-up time ⁽²⁾		45		μs

(2) During power on, V_S must exceed 3.3 V for t_{ON} before the output is in a correct state.

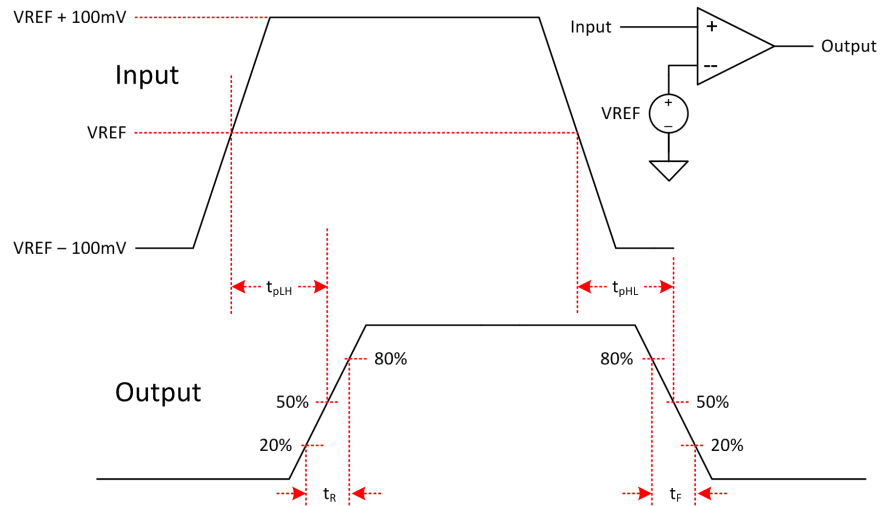

Figure 1. Propagation Delay

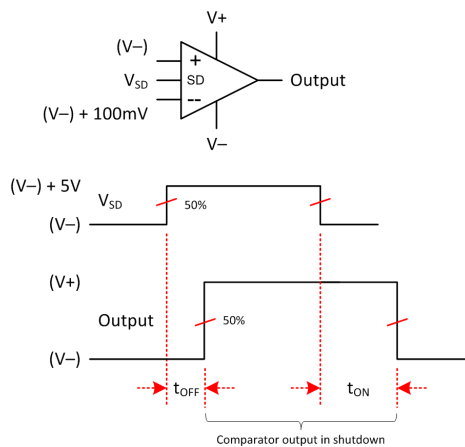
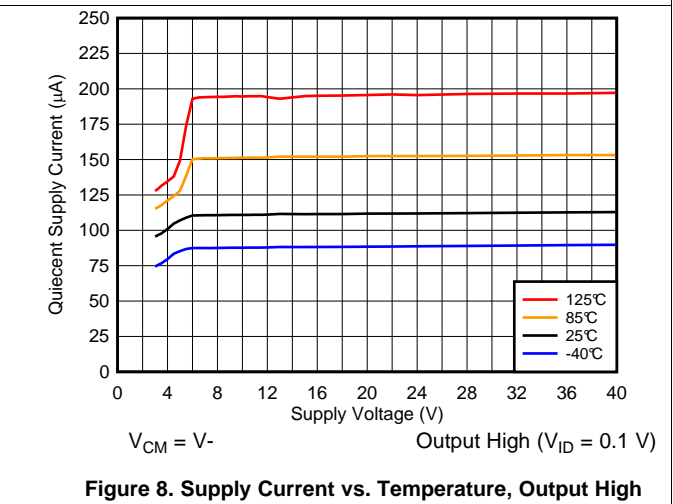
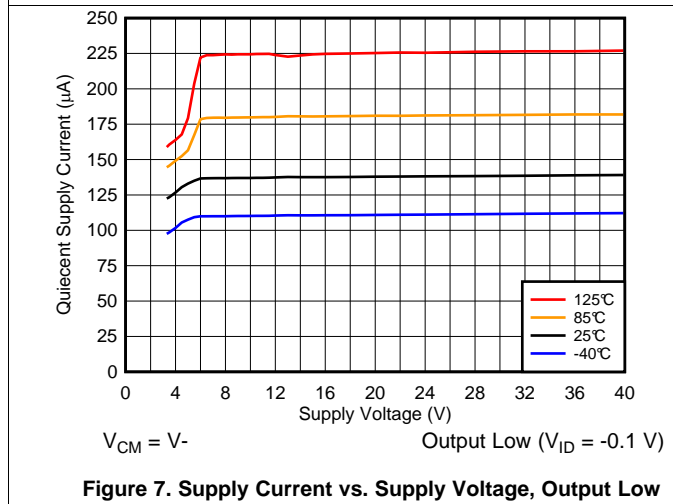
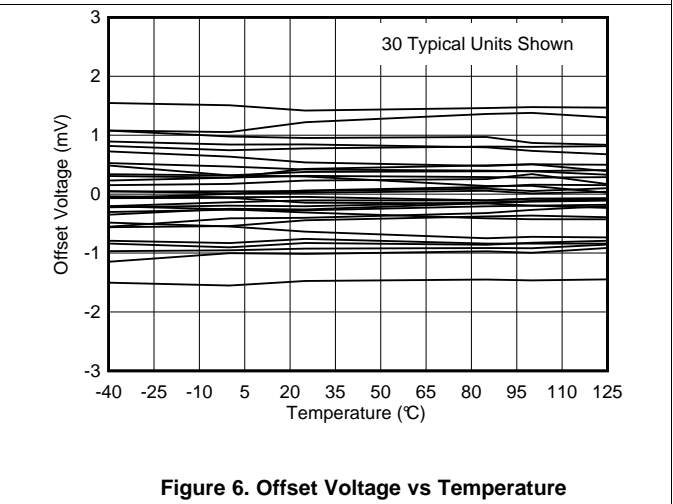
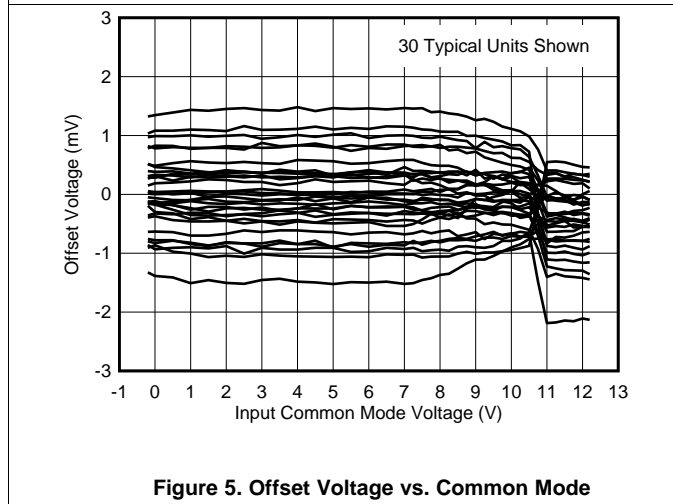
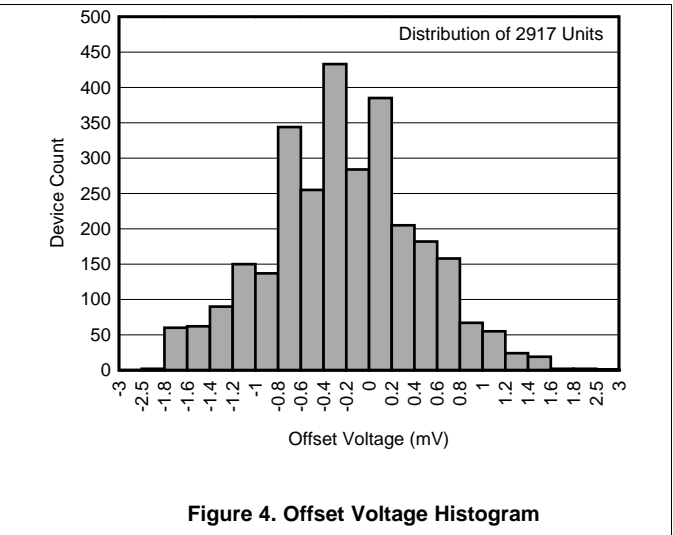
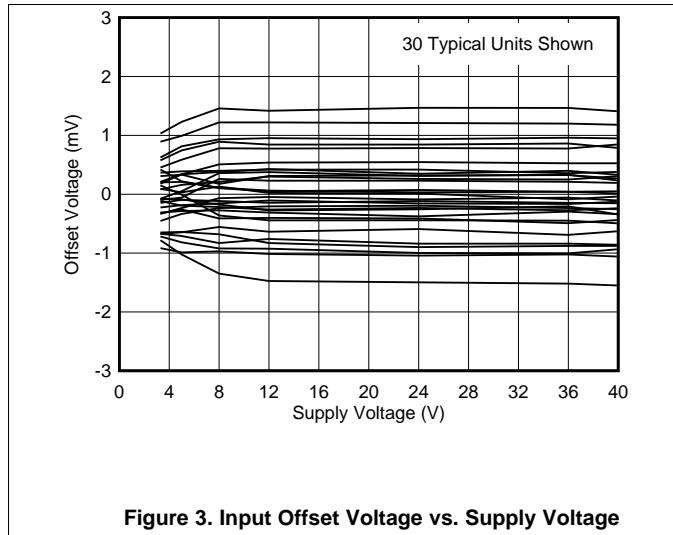

Figure 2. Shutdown Timing

6.7 Typical Characteristics

at $T_A = 25^\circ\text{C}$, $V_S = 12\text{ V}$, $V_{CM} = V_S/2$, and input overdrive = 100 mV (unless otherwise noted)



Typical Characteristics (continued)

at $T_A = 25^\circ\text{C}$, $V_S = 12\text{ V}$, $V_{CM} = V_S/2$, and input overdrive = 100 mV (unless otherwise noted)

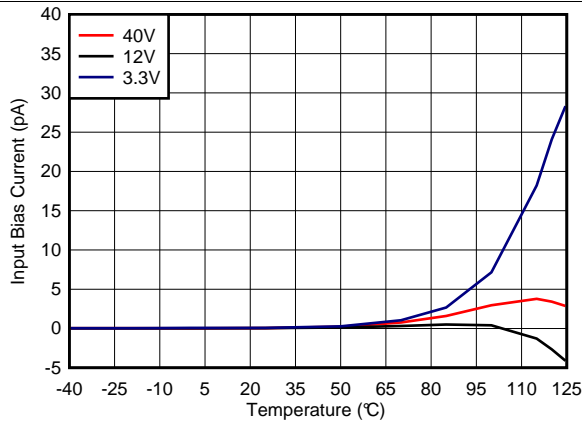

Figure 9. Input Bias Current vs. Temperature

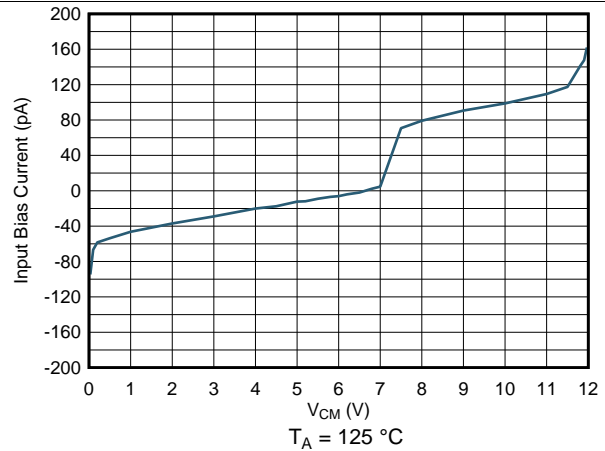

Figure 10. Input Bias Current vs. Common Mode, 125°C

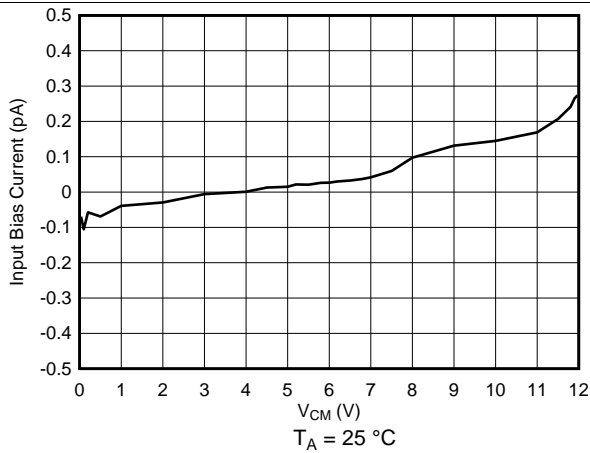

Figure 11. Input Bias Current vs. Common Mode, 25°C

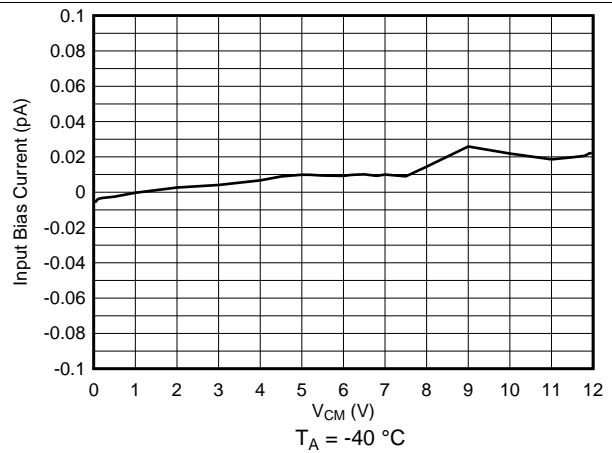

Figure 12. Input Bias Current vs. Common Mode, -40°C

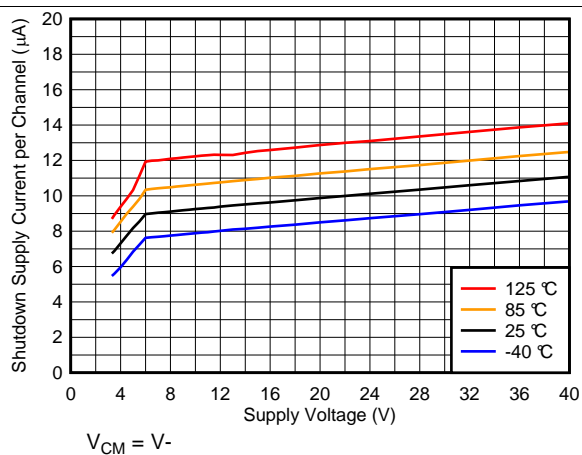

Figure 13. Shutdown Supply Current vs. Supply Voltage

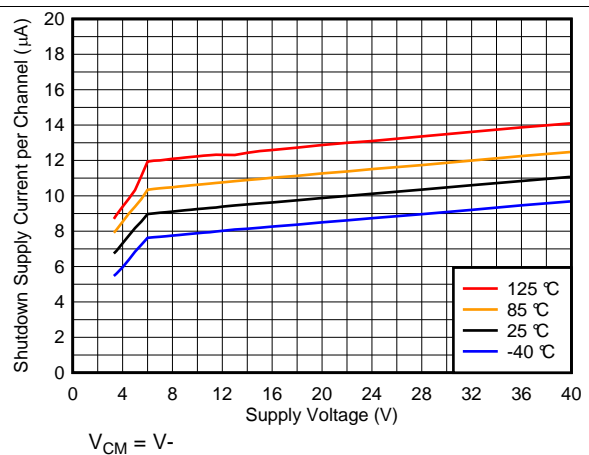

Figure 14. Shutdown Supply Current vs. Supply Voltage

Typical Characteristics (continued)

at $T_A = 25^\circ\text{C}$, $V_S = 12\text{ V}$, $V_{CM} = V_S/2$, and input overdrive = 100 mV (unless otherwise noted)

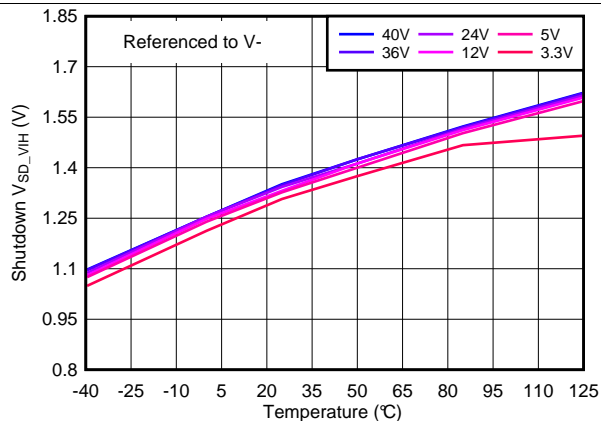

Figure 15. Shutdown Voltage High Threshold vs. Temperature

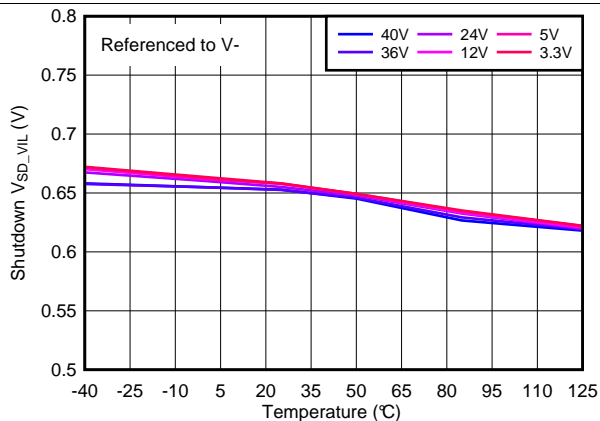

Figure 16. Shutdown Voltage Low Threshold vs. Temperature

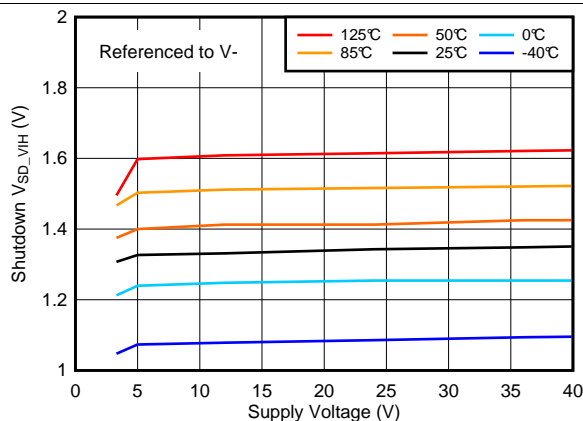

Figure 17. Shutdown Voltage High Threshold vs. Supply Voltage

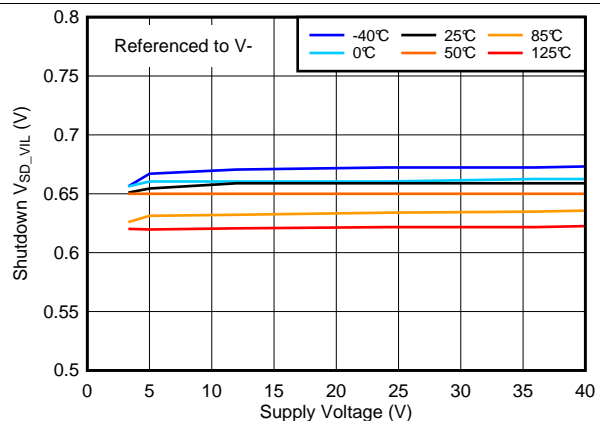

Figure 18. Shutdown Voltage Low Threshold vs. Supply Voltage

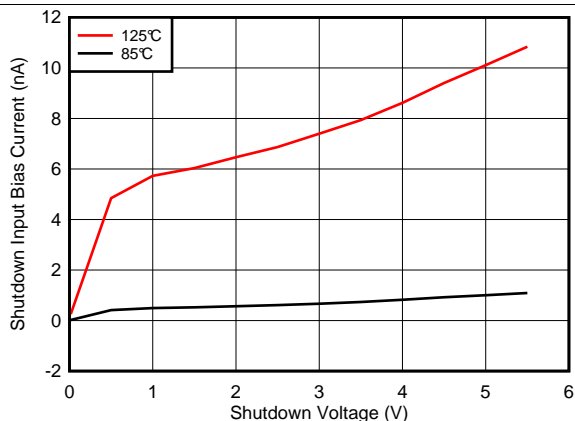

Figure 19. Shutdown Input Bias Current vs. Shutdown Input Voltage, High Temperatures

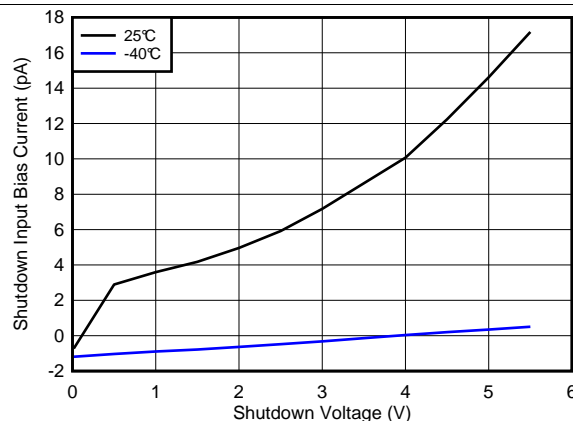

Figure 20. Shutdown Input Bias Current vs. Shutdown Input Voltage, Low Temperatures

Typical Characteristics (continued)

at $T_A = 25^\circ\text{C}$, $V_S = 12\text{ V}$, $V_{CM} = V_S/2$, and input overdrive = 100 mV (unless otherwise noted)

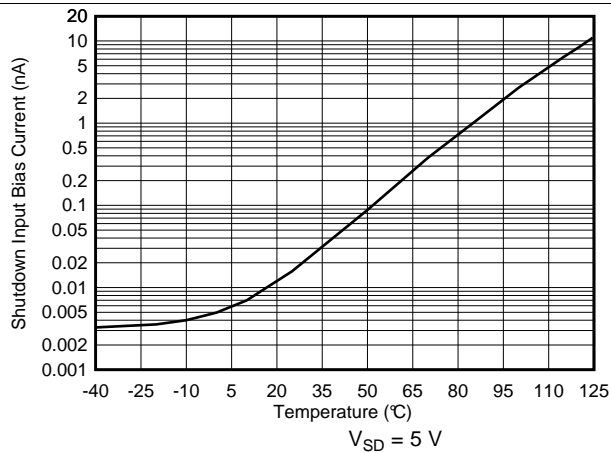

Figure 21. Shutdown Input Bias Current vs. Temperature

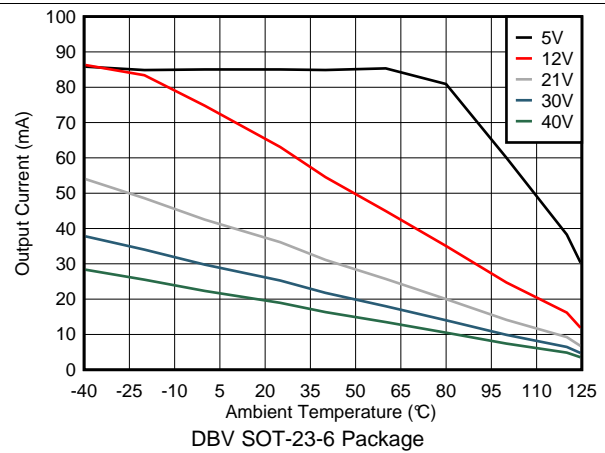
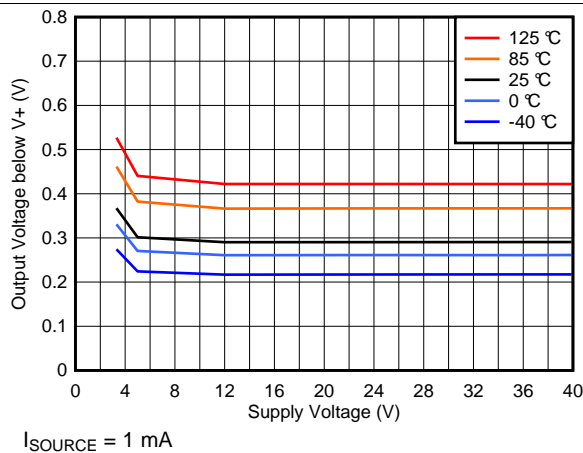
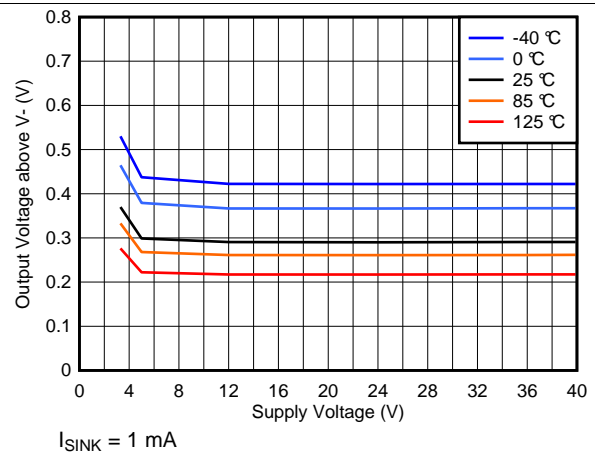

Figure 22. Maximum Output Current vs. Ambient Temperature
DBV SOT-23-6 Package



$I_{SOURCE} = 1\text{ mA}$

Figure 23. Output High Voltage vs. Supply Voltage



$I_{SINK} = 1\text{ mA}$

Figure 24. Output Low Voltage vs. Supply Voltage

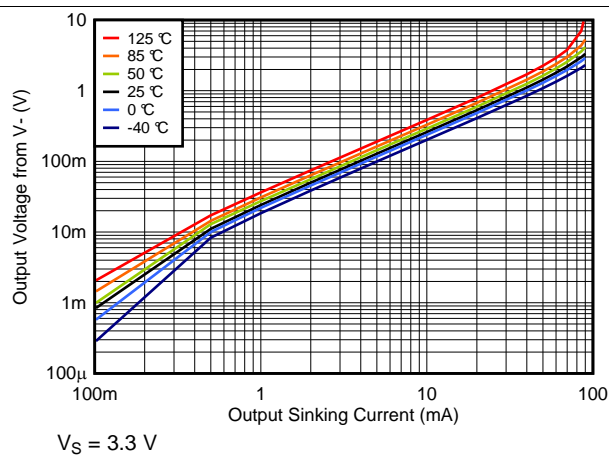

$V_S = 3.3\text{ V}$

Figure 25. Output Sinking Current vs. Output Voltage at 3.3V

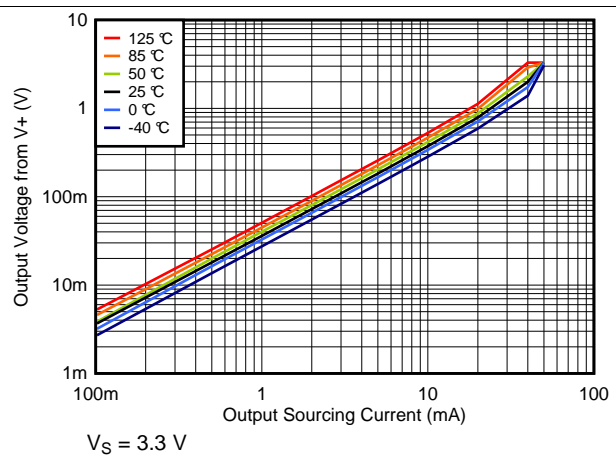

$V_S = 3.3\text{ V}$

Figure 26. Output Sourcing Current vs. Output Voltage at 3.3V

Typical Characteristics (continued)

at $T_A = 25^\circ\text{C}$, $V_S = 12\text{ V}$, $V_{CM} = V_S/2$, and input overdrive = 100 mV (unless otherwise noted)

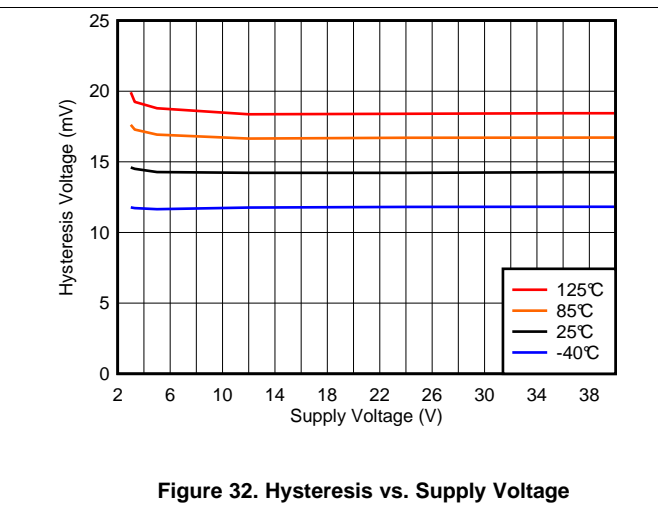
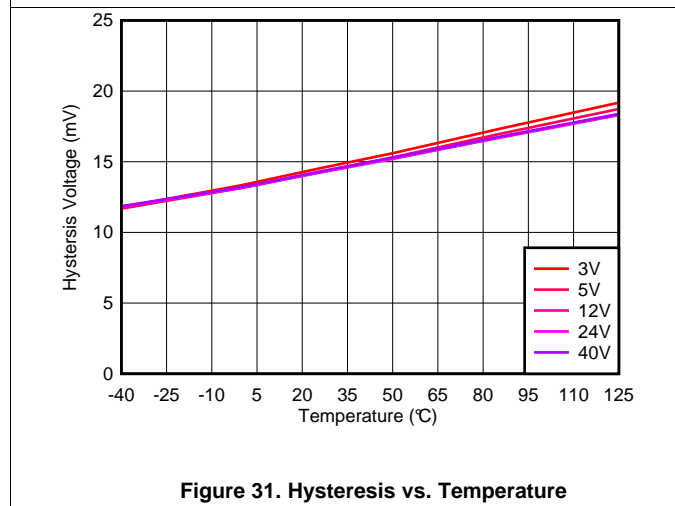
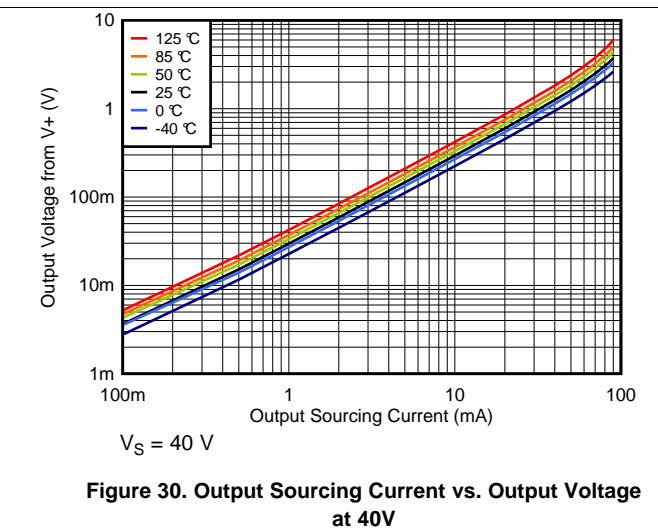
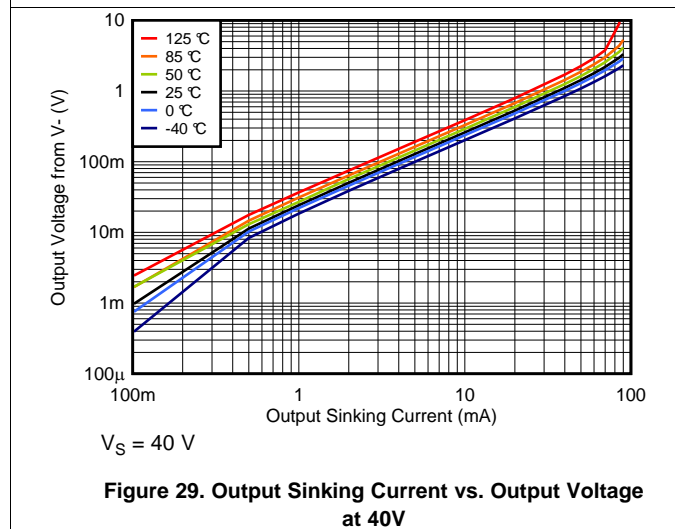
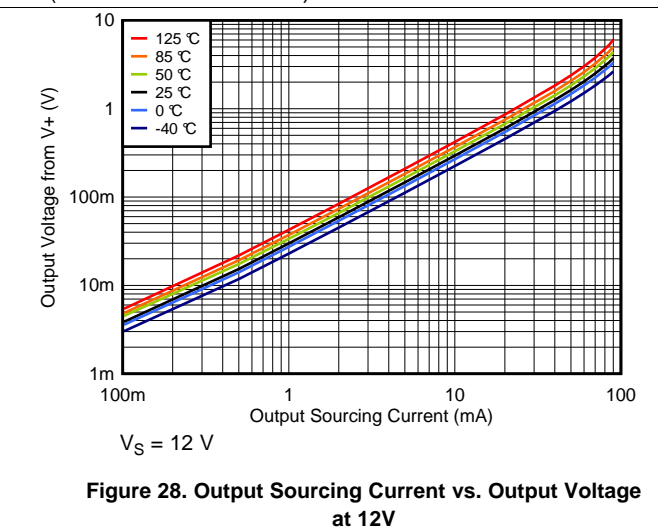
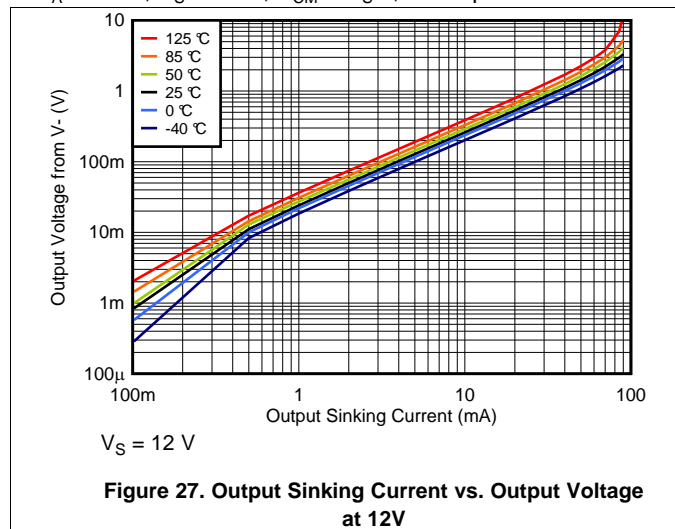

Typical Characteristics (continued)

at $T_A = 25^\circ\text{C}$, $V_S = 12\text{ V}$, $V_{CM} = V_S/2$, and input overdrive = 100 mV (unless otherwise noted)

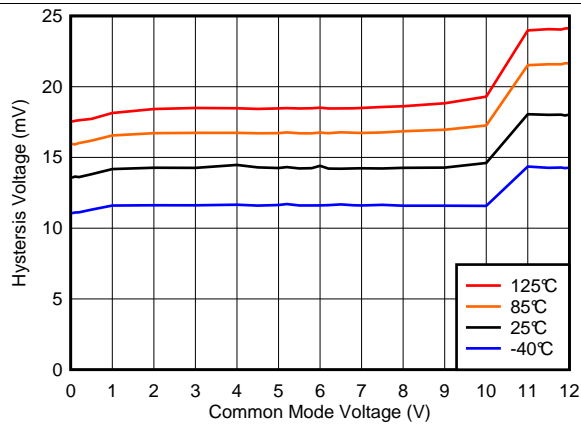

Figure 33. Hysteresis vs Common-Mode Voltage

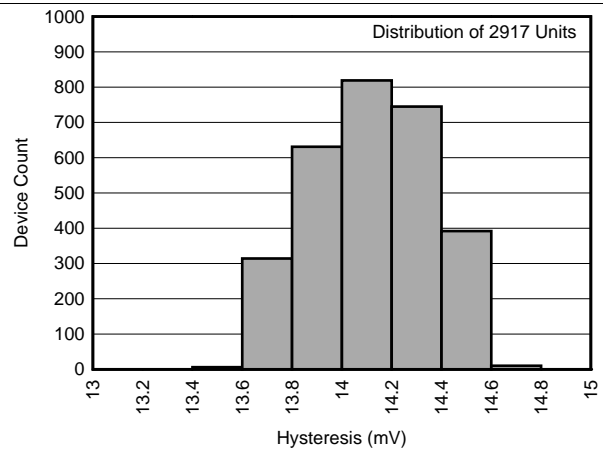

Figure 34. Hysteresis Histogram

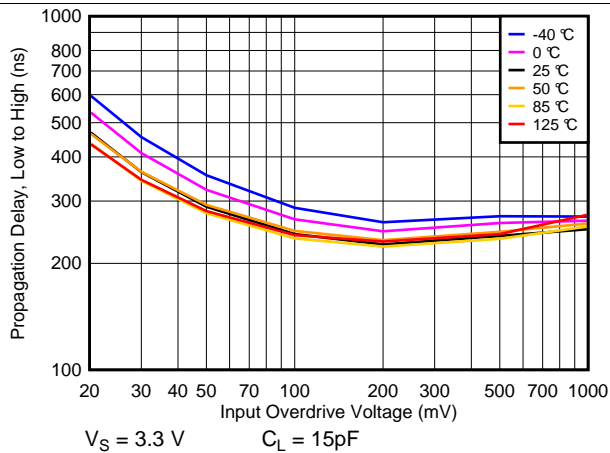

Figure 35. T_{PLH} Response Time vs. Overdrive at 3.3V

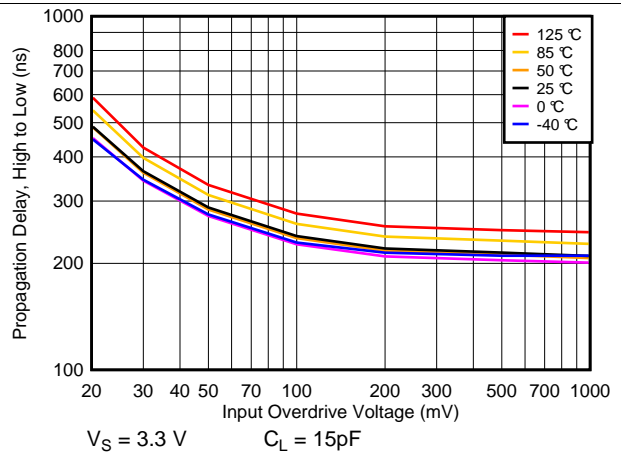

Figure 36. T_{PHL} Response Time vs. Overdrive at 3.3V

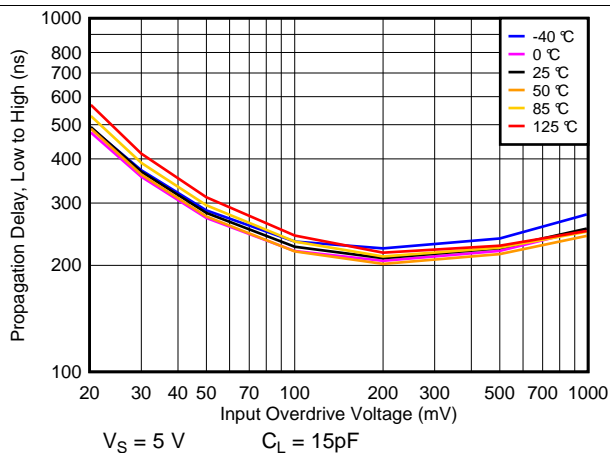

Figure 37. T_{PLH} Response Time vs. Overdrive at 5V

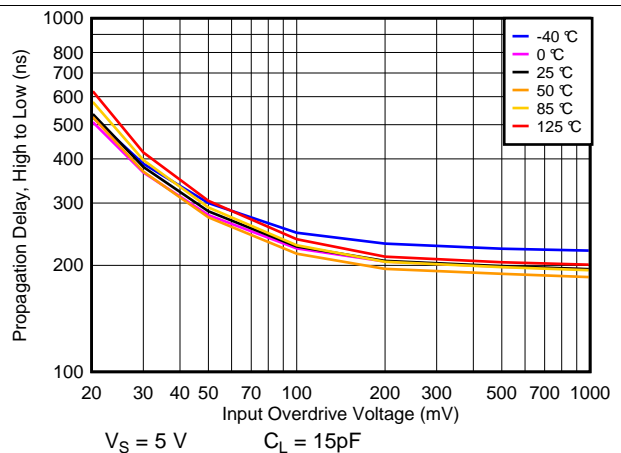

Figure 38. T_{PHL} Response Time vs. Overdrive at 5V

Typical Characteristics (continued)

at $T_A = 25^\circ\text{C}$, $V_S = 12\text{ V}$, $V_{CM} = V_S/2$, and input overdrive = 100 mV (unless otherwise noted)

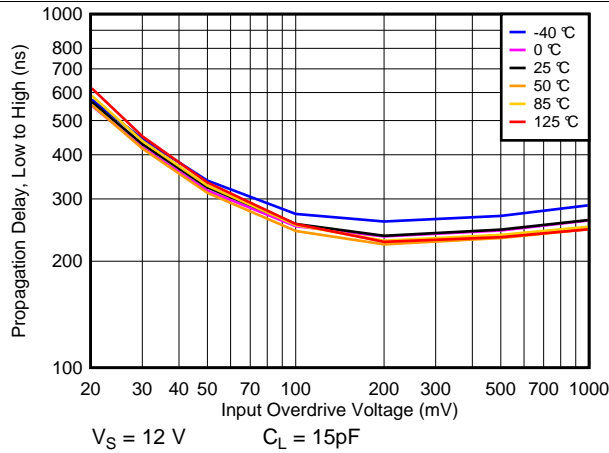

Figure 39. T_{PLH} Response Time vs. Overdrive at 12V

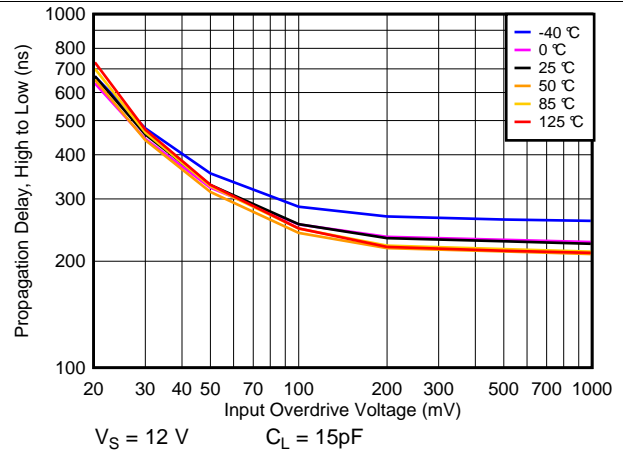

Figure 40. T_{PHL} Response Time vs. Overdrive at 12V

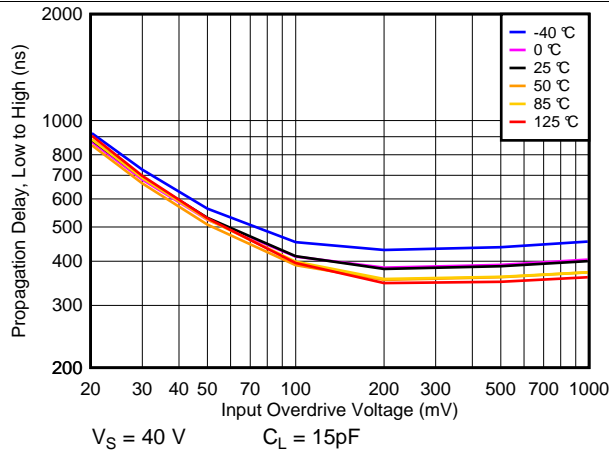

Figure 41. T_{PLH} Response Time vs. Overdrive at 40V

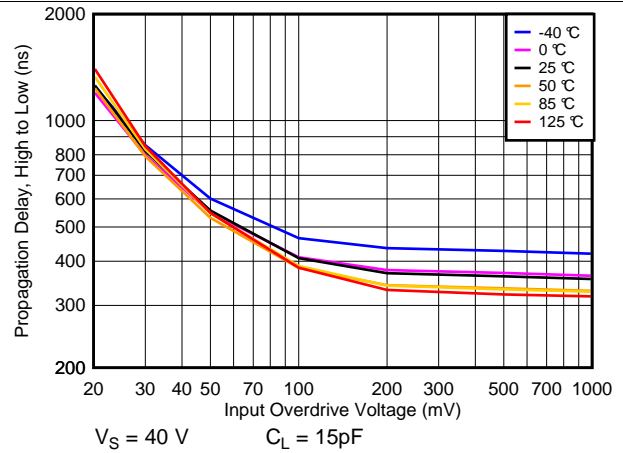

Figure 42. T_{PHL} Response Time vs. Overdrive at 40V

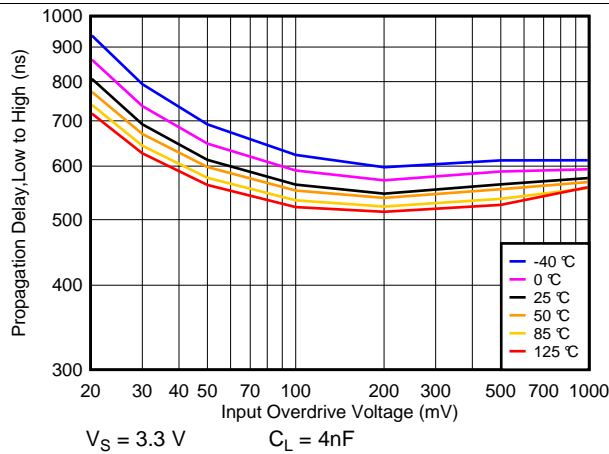

Figure 43. T_{PLH} Response Time vs. Overdrive at 3.3V

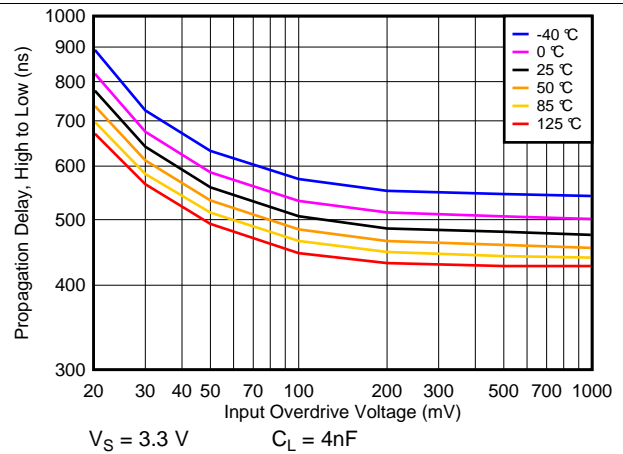
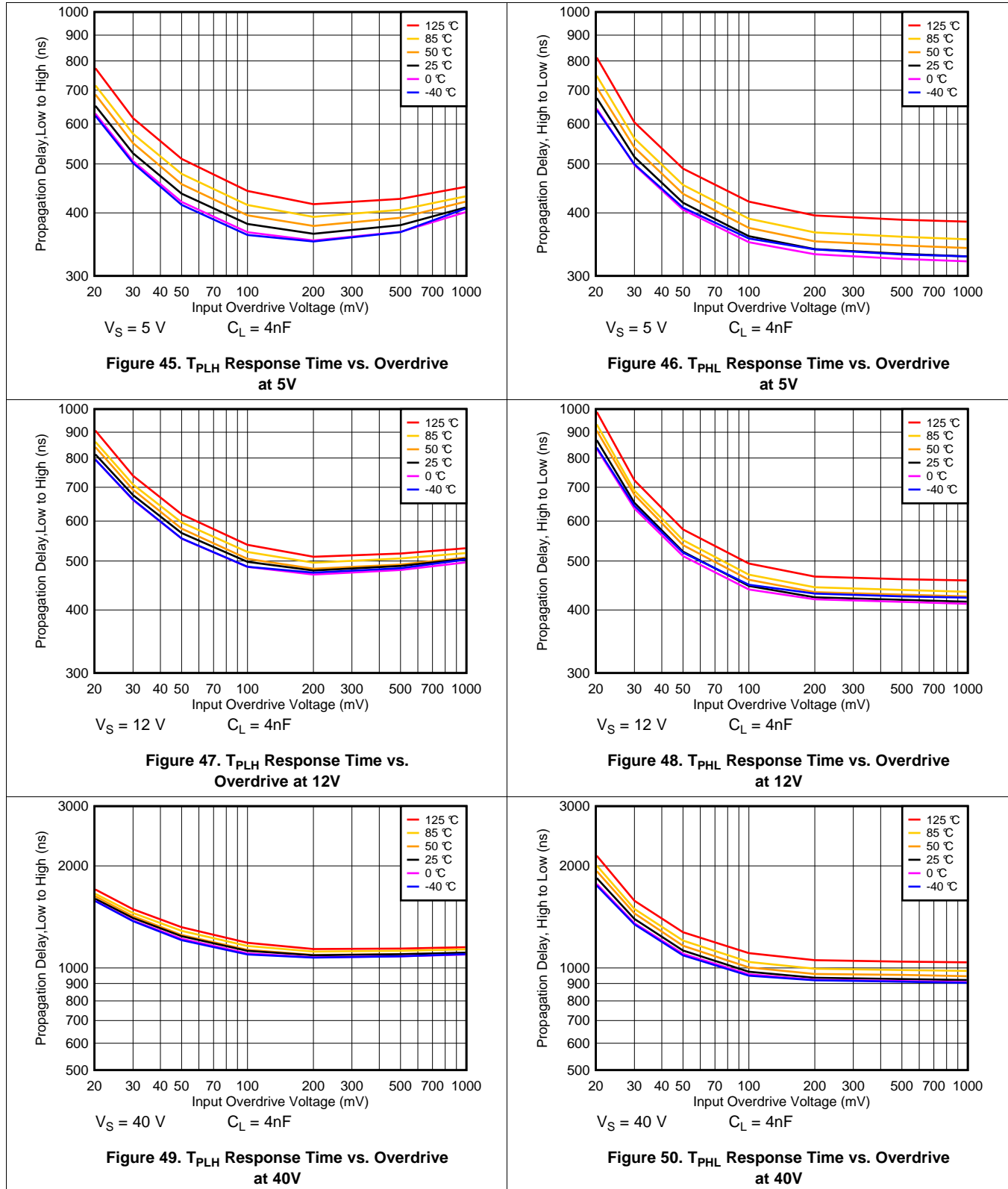

Figure 44. T_{PHL} Response Time vs. Overdrive at 3.3V

Typical Characteristics (continued)

at $T_A = 25^\circ\text{C}$, $V_S = 12\text{ V}$, $V_{CM} = V_S/2$, and input overdrive = 100 mV (unless otherwise noted)



Typical Characteristics (continued)

at $T_A = 25^\circ\text{C}$, $V_S = 12\text{ V}$, $V_{CM} = V_S/2$, and input overdrive = 100 mV (unless otherwise noted)

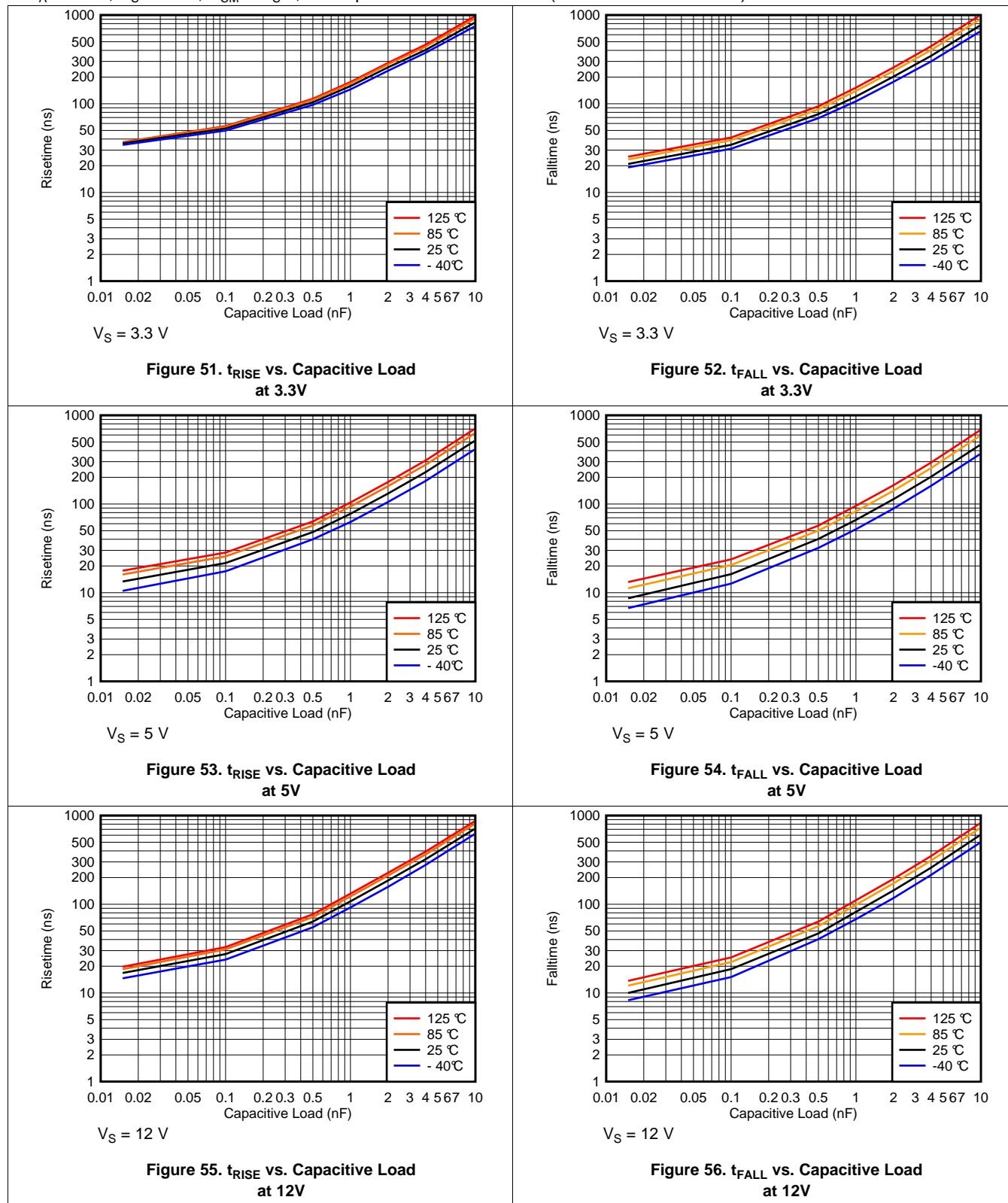

Typical Characteristics (continued)

at $T_A = 25^\circ\text{C}$, $V_S = 12\text{ V}$, $V_{CM} = V_S/2$, and input overdrive = 100 mV (unless otherwise noted)

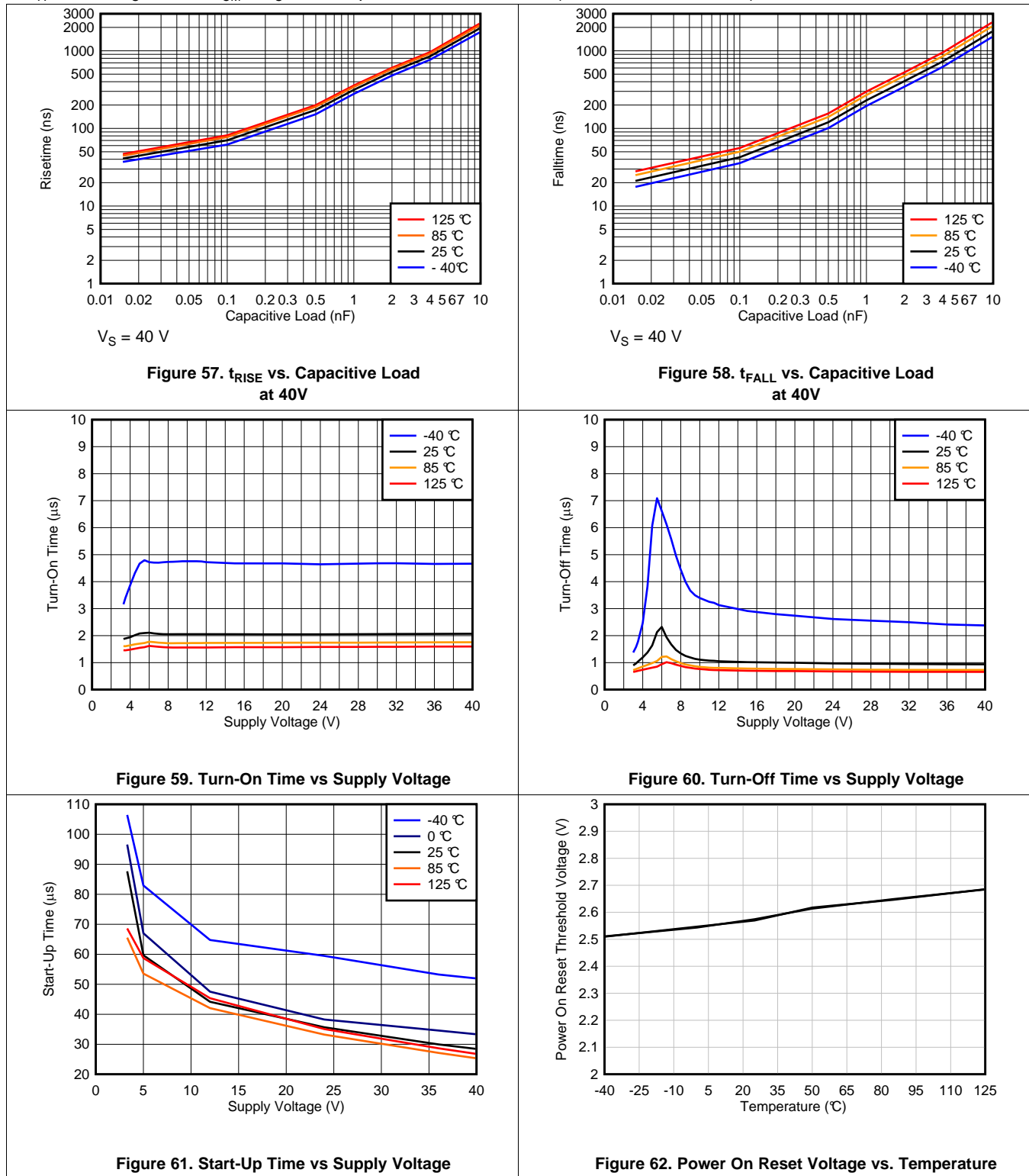

7 Detailed Description

7.1 Overview

The TLV1805 comparator features a rail-to-rail inputs with a push-pull output stage that operates at supply voltages as high as 40 V or ± 20 V. The rail-to-rail input stage enables detection of signals close to the supply and ground while the push-pull output stage creates fast transition edges to either supply rail. A low supply current of 135 μ A per channel with small, space-saving packages, makes these comparators versatile for use in a wide range of applications, from portable to industrial.

7.2 Functional Block Diagram

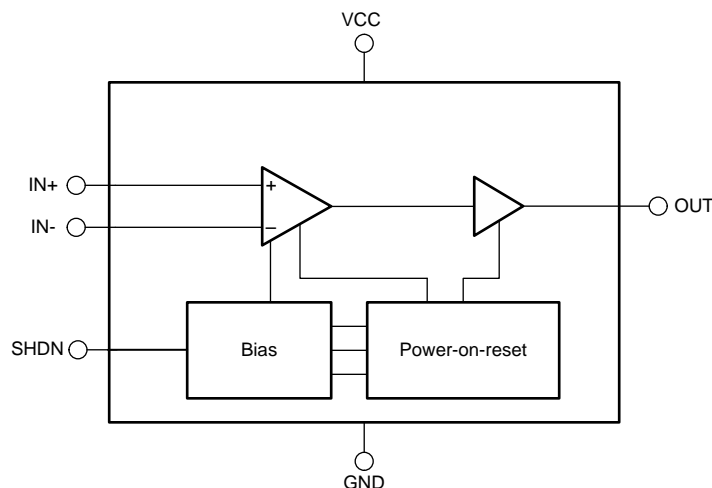

7.3 Feature Description

7.3.1 Rail to Rail Inputs

The TLV1805 comparator features a CMOS input with a common-mode range that includes both supply rails. The TLV1805-Q1 is designed to prevent phase inversion when the input pins exceed the supply voltage.

7.3.2 Power On Reset

The TLV1805 incorporates a power-on reset that holds the output in a High-Z state until the minimum operating supply voltage has been reached for at least 20 μ s. After this time the output will start responding to the inputs. This feature prevents false outputs during power-up and power-down.

7.3.3 High Power Push-Pull Output

The push-pull output stage, which is unique for high-voltage comparators, offers the advantage of allowing the output to actively drive the load to either supply rail with a fast edge rate. A high output sink and source peak current of over 100mA allows quickly charging and discharging capacitive loads such as cables and power MOSFET gates. Caution must be taken to ensure that the package power dissipation is not exceeded when switching at these high supply voltages. See [Figure 22](#) for the output current derating curve.

7.3.4 Shutdown Function

The TLV1805 has a logic level SHDN input. When the shutdown SHDN input is 1.4V above V_{-} , the TLV1805 is disabled. When disabled, the output becomes high impedance (Hi-Z), and the supply current drops to below 10 μ A. The input bias current remains unchanged. Voltages may still be applied to the comparator inputs as long as V_{+} power is still applied and the applied input voltages are still within the specified input voltage range.

Feature Description (continued)

CAUTION

The maximum voltage on the shutdown pin is +5.5V referred to V-, regardless of supply voltage. Connect the SHDN pin to V- if shutdown is not used. Do not float the SHDN pin.

A high value pull-up or pull-down resistor on the output may be required if a specific logic level is required during shutdown (when the output is High-Z). This prevents logic inputs from floating to illegal states when the comparator output is in High-Z mode.

Since the Shutdown threshold voltage is a tested parameter, the shutdown pin can also be used as a second comparison input to provide a secondary measurement, such as overvoltage monitoring, as shown in the [P-Channel Reverse Current Protection With Overvoltage Protection](#) circuit.

7.3.5 Internal Hysteresis

The TLV1805 contains 14mV of internal hysteresis.

The hysteresis transfer curve is shown in [Figure 63](#). This curve is a function of three components: V_{TH} , V_{OS} , and V_{HYST} :

- V_{TH} is the actual set voltage or threshold trip voltage.
- V_{OS} is the internal offset voltage between V_{IN+} and V_{IN-} . This voltage is added to V_{TH} to form the actual trip point at which the comparator must respond to change output states.
- V_{HYST} is the internal hysteresis (or trip window) that is designed to reduce comparator sensitivity to noise (14 mV for the TLV1805).

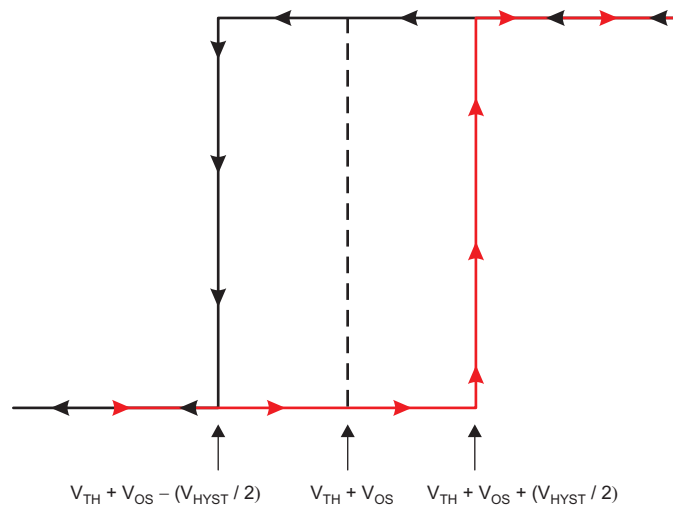

Figure 63. Hysteresis Transfer Curve

7.4 Device Functional Modes

7.4.1 External Hysteresis

External Hysteresis may be added to further improve response to noisy or slow-moving input signals.

Device Functional Modes (continued)

7.4.1.1 Inverting Comparator With Hysteresis

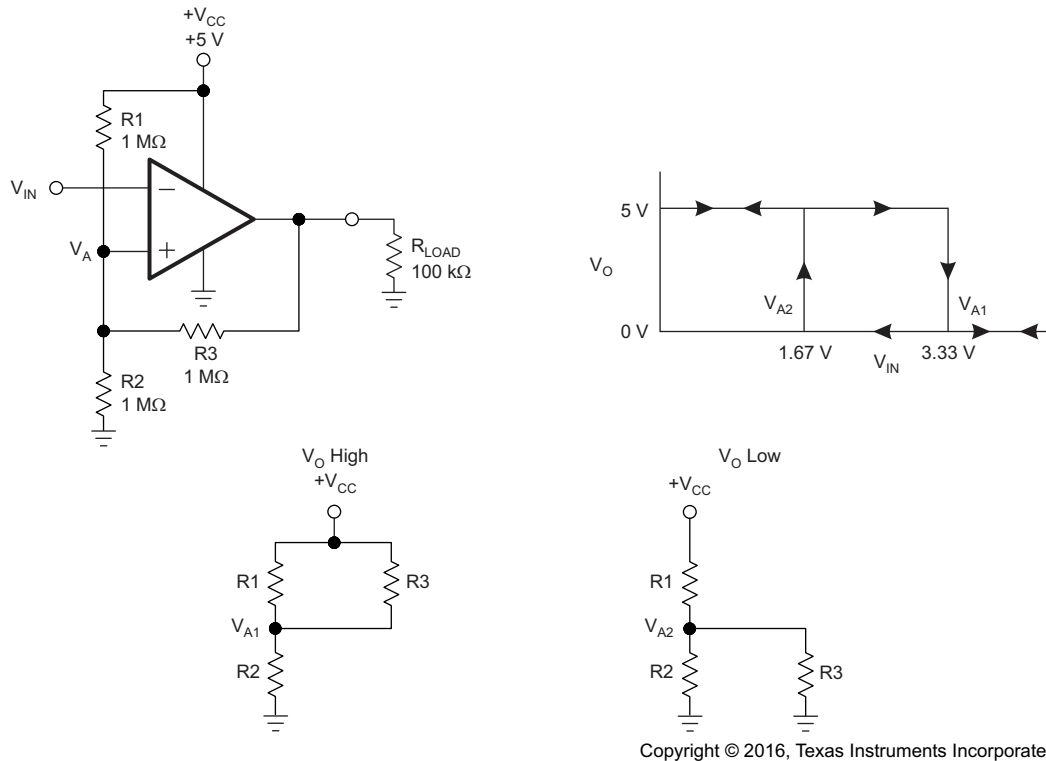

Figure 64. TLV1805 in an Inverting Configuration With Hysteresis

The inverting comparator with hysteresis requires a three-resistor network that is referenced to the comparator supply voltage (V_{CC}), as shown in Figure 64. When V_{IN} at the inverting input is less than V_A , the output voltage is high (for simplicity, assume V_O switches as high as V_{CC}). The three network resistors can be represented as $R1 \parallel R3$ in series with $R2$. Equation 1 defines the high-to-low trip voltage (V_{A1}).

$$V_{A1} = V_{CC} \times \frac{R2}{(R1 \parallel R3) + R2} \quad (1)$$

When V_{IN} is greater than V_A , the output voltage is low, very close to ground. In this case, the three network resistors can be presented as $R2 \parallel R3$ in series with $R1$. Use Equation 2 to define the low to high trip voltage (V_{A2}).

$$V_{A2} = V_{CC} \times \frac{R2 \parallel R3}{R1 + (R2 \parallel R3)} \quad (2)$$

Equation 3 defines the total hysteresis provided by the network.

$$\Delta V_A = V_{A1} - V_{A2} \quad (3)$$

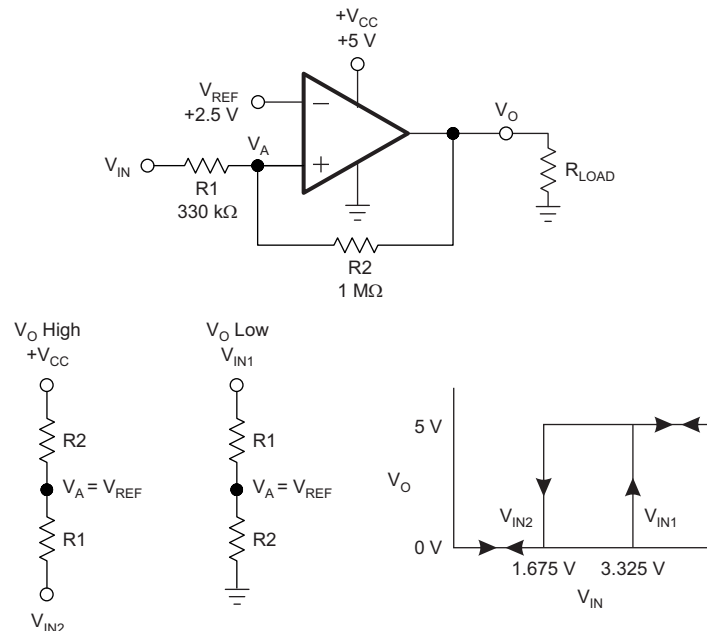
Device Functional Modes (continued)
7.4.1.2 Noninverting Comparator With Hysteresis

Copyright © 2016, Texas Instruments Incorporated

Figure 65. TLV1805-Q1 in a Noninverting Configuration With Hysteresis

A noninverting comparator with hysteresis requires a two-resistor network, as shown in [Figure 65](#), and a voltage reference (V_{REF}) at the inverting input. When V_{IN} is low, the output is also low. For the output to switch from low to high, V_{IN} must rise to V_{IN1} . Use [Equation 4](#) to calculate V_{IN1} .

$$V_{IN1} = R1 \times \frac{V_{REF}}{R2} + V_{REF} \quad (4)$$

When V_{IN} is high, the output is also high. For the comparator to switch back to a low state, V_{IN} must drop to V_{IN2} such that V_A is equal to V_{REF} . Use [Equation 5](#) to calculate V_{IN2} .

$$V_{IN2} = \frac{V_{REF} (R1 + R2) - V_{CC} \times R1}{R2} \quad (5)$$

The hysteresis of this circuit is the difference between V_{IN1} and V_{IN2} , as shown in [Equation 6](#).

$$\Delta V_{IN} = V_{CC} \times \frac{R1}{R2} \quad (6)$$

8 Application and Implementation

NOTE

Information in the following applications sections is not part of the TI component specification, and TI does not warrant its accuracy or completeness. TI's customers are responsible for determining suitability of components for their purposes. Customers should validate and test their design implementation to confirm system functionality.

8.1 Application Information

The TLV1805 family of devices can be used in a wide variety of applications, such as MOSFET gate drivers, zero crossing detectors, window comparators, over and undervoltage detectors, and high-side voltage sense circuits.

8.2 Typical Applications

Comparators are used to differentiate between two different signal levels. For example, a comparator differentiates between an over-temperature and normal-temperature condition. However, noise or signal variation at the comparison threshold causes multiple transitions. This application example sets upper and lower hysteresis thresholds to eliminate the multiple transitions caused by noise.

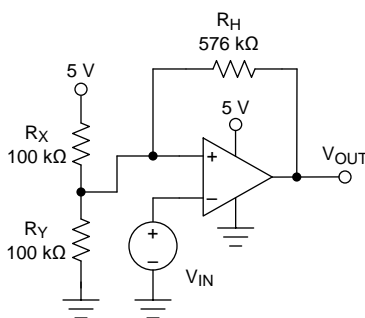

Figure 66. Comparator with Hysteresis

8.2.1 Design Requirements

The design requirements are as follows:

- Supply voltage: 5 V
- Input: 0 V to 5 V
- Lower threshold (V_L) = 2.3 V \pm 0.1 V
- Upper threshold (V_H) = 2.7 V \pm 0.1 V
- $V_H - V_L = 2.4$ V \pm 0.1 V
- Low-power consumption

8.2.2 Detailed Design Procedure

A small change to the comparator circuit can be made to add hysteresis. Hysteresis uses two different threshold voltages to avoid the multiple transitions introduced in the previous circuit. The input signal must exceed the upper threshold (V_H) to transition low, or below the lower threshold (V_L) to transition high.

Figure 66 illustrates hysteresis on a comparator. Resistor R_H sets the hysteresis level.

When the output is at a logic high (5 V), R_H is in parallel with R_X . This configuration drives more current into R_Y , and raises the threshold voltage (V_H) to 2.7 V. The input signal must drive above $V_H = 2.7$ V to cause the output to transition to logic low (0 V).

Typical Applications (continued)

When the output is at logic low (0 V), R_h is in parallel with R_y . This configuration reduces the current into R_y , and reduces the threshold voltage to 2.3 V. The input signal must drive below $V_L = 2.3$ V to cause the output to transition to logic high (5 V).

For more details on this design, refer to Precision Design [TIPD144](#), *Comparator with Hysteresis Reference Design*.

8.2.3 Application Curve

Figure 67 shows the upper and lower thresholds for hysteresis. The upper threshold is 2.76 V and the lower threshold is 2.34 V, both of which are close to the design target.

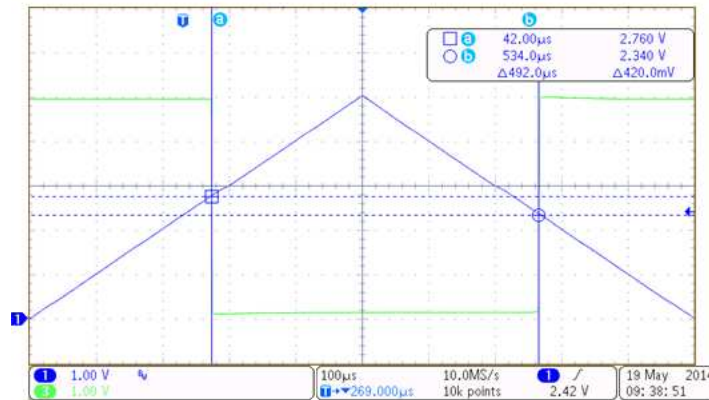

Figure 67. TLV1805 Upper and Lower Threshold with Hysteresis

Typical Applications (continued)

8.2.4 Reverse Current Protection Using MOSFET and TLV1805

An N-Channel or P-Channel MOSFET may be used to protect against reverse current. Reverse current is defined as current flowing from the load (V_{LOAD}) to the source (V_{BATT}). Both the P-Channel and N-Channel circuits work on the same basic principle, where a comparator monitors the voltage across the MOSFET's Source and Drain terminals (monitoring V_{DS}). The described circuits also protect against reverse voltage.

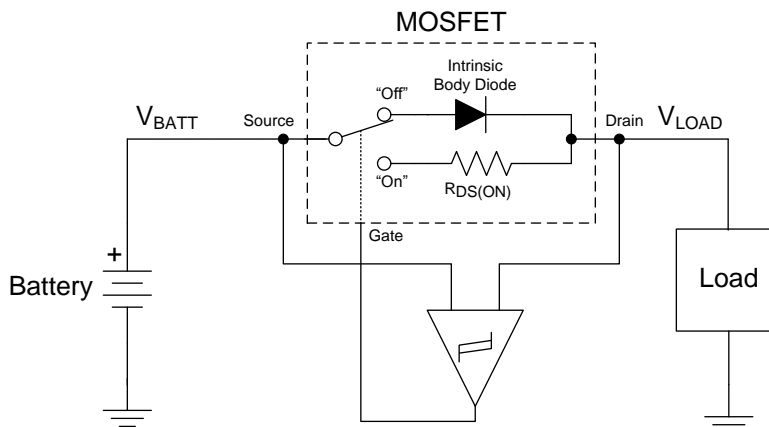

Figure 68. Simplified Operational Theory

When the current is flowing from the battery (V_{BATT}) to the load (V_{LOAD}), the battery voltage will be higher than the load voltage due to voltage drop across the MOSFET caused by the $R_{DS(ON)}$ or the intrinsic body diode forward voltage drop. The comparator will detect this and turn "on" the MOSFET so that the load current is now flowing through the low loss $R_{DS(ON)}$ path.

In a reverse current condition, V_{LOAD} will be higher than V_{BATT} . The comparator will detect this and drive the gate to set $V_{GS} = 0$ to turn "off" the MOSFET (non-conducting). The body diode is reverse biased and will block current flow.

For a P-Channel MOSFET, the gate must be driven at least 4V or more *below* the battery voltage to turn "on" the MOSFET.

For a N-Channel MOSFET, the gate must be driven 4V or more *above* the battery voltage to turn "on" the MOSFET. If a higher voltage is not available in the system, a charge pump is usually required to generate a voltage higher than the battery voltage to provide the necessary positive gate drive voltage.

8.2.4.1 Minimum Reverse Current

There is a minimum amount of reverse current that is needed to trip the comparator. To detect this reverse current, a voltage must be dropped across the MOSFET (V_{MEAS}).

When the MOSFET is off, V_{GS} will be in the -600mV to -1V range due to the forward voltage drop (V_F) of the MOSFET body diode. Response to this large voltage will be immediate.

However, with the MOSFET "on" (conducting), the current required to create the trip voltage will be much greater. The trip voltage drop required across the MOSFET $R_{DS(ON)}$ will be the comparator offset voltage plus half of the hysteresis.

The maximum offset voltage of the TLV1805 is 5mV with a typical hysteresis of 14mV. The trip voltage can be calculated from:

$$V_{TRIP} = V_{OS(max)} + (V_{HYST} / 2) = 5 \text{ mV} + 7 \text{ mV} = 12 \text{ mV} \quad (7)$$

The actual current trip point will depend on the MOSFET $R_{DS(ON)}$ and V_{GS} drive level. Assuming the MOSFET has a 22 m Ω on resistance, the trip current is found from:

$$I_{TRIP} = V_{TRIP} / R_{DS(ON)} = 12 \text{ mV} / 22 \text{ m}\Omega = 546\text{mA} \quad (8)$$

Typical Applications (continued)

8.2.4.2 N-Channel Reverse Current Protection Circuit

In order to turn "on" the N-Channel MOSFET, the MOSFET gate must be brought "High" above V_{BATT} . If a higher voltage is not available, a charge pump circuit is required to provide the comparator with a supply voltage above V_{BATT} .

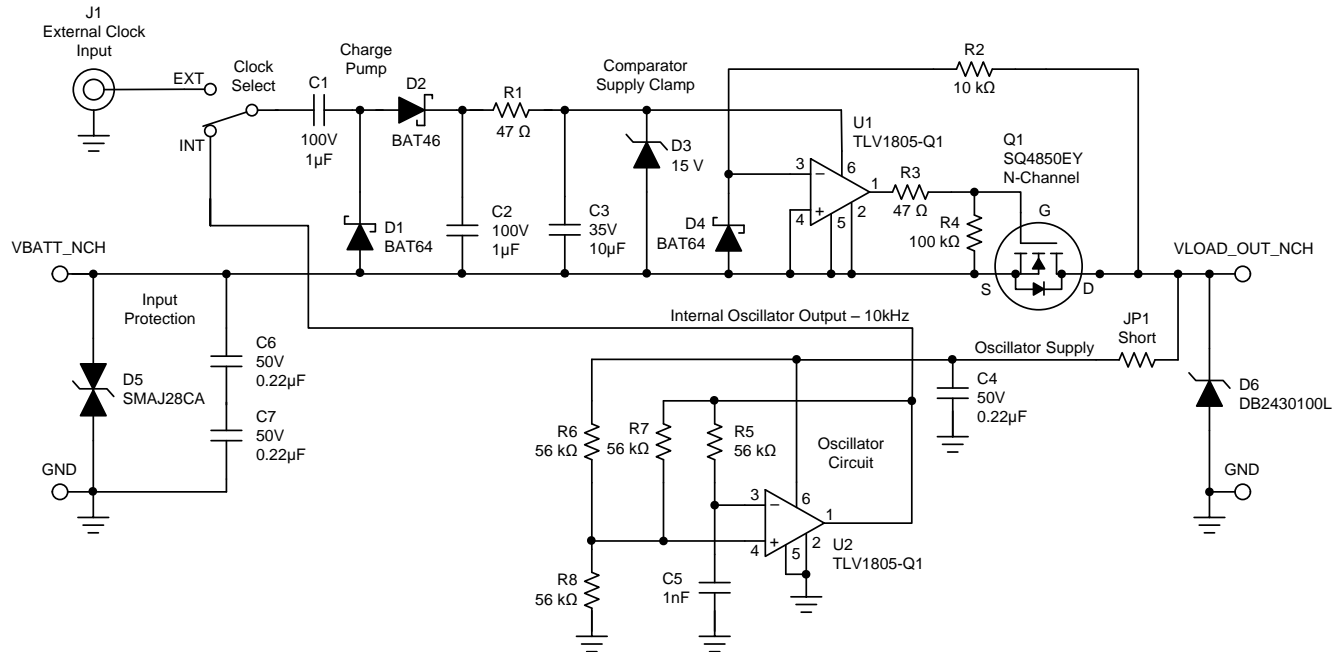

Figure 69. N-Channel Reverse Current Schematic with Oscillator

C1, D1, D2 & C2 form the charge pump. The AC drive signal is applied through C1 into the charge pump. The result is a voltage across C2 that is approximately equal to the peak-to-peak amplitude of the AC waveform, minus 700mV. If a 12Vpp waveform is applied to the C1 input, 11.3V will be generated across C2. This voltage is on top of the V_{BATT} voltage, so the voltage seen from the D2-C2 junction ground is 23.3V. This provides the needed higher voltage to drive the MOSFET and power the comparator.

An external oscillator source may be used, such as the gate drive output of a switcher, system clock or any available clock source in the 1kHz to 10MHz range. The charge pump should be fed by a 50 percent duty cycle square wave source of 5Vpp or more. Since the input capacitor of the charge-pump effectively AC-couples the input, the oscillator may be ground referenced.

R1 and D3 form the comparator supply clamp to limit the gate drive to prevent exceeding the $V_{GS(MAX)}$ of the MOSFET during an overvoltage event. R1 must be sized to dissipate any expected overvoltage.

D4 and R2 clamp the input should V_{BATT} drop below V_{LOAD} (as in a supply reversal).

The output diode D6 is used to anchor the output during light or floating loads. At light or no loads, there is a possibility the MOSFET could turn on due to the comparator offset voltage. The diode provides enough of a negative leakage to turn the MOSFET off.

8.2.4.2.1 N-Channel Oscillator Circuit

The oscillation frequency is determined by R5 and C5. The default configuration oscillates around 10kHz (depending on RC component tolerances). For further information on selecting these RC values, please see the Engineers Cookbook Circuit entitled [Oscillator Circuit \(SNOA990\)](#). Do note that R5 does present an AC load to the oscillator output, and should be sized appropriately to minimize the peak charging currents of C5 (use large resistors and small capacitors).

Typical Applications (continued)

The output amplitude is roughly equivalent to the V_{LOAD} voltage minus the TLV1805 output saturation (approximately 300mV). With a maximum supply voltage of 40V for the TLV1805, the oscillator circuit is capable of generating up to 39Vpp!

The TLV1805 oscillator typically starts oscillating when V_{LOAD} reaches 2.8V, though full specified operation does not occur until 3.3V.

For more information, please see the TLV1805-Q1 Evaluation Module Users Guide [TLV1805-Q1 Evaluation Module Users Guide \(SNOU158\)](#).

8.2.5 P-Channel Reverse Current Protection Circuit

Figure 70 shows the P-Channel circuit. In order to turn "on" the P-Channel MOSFET, the gate must be brought "Low" below V_{BATT} . To accomplish this, the comparators inverting input is tied to the battery side of the MOSFET to set the output low during forward current.

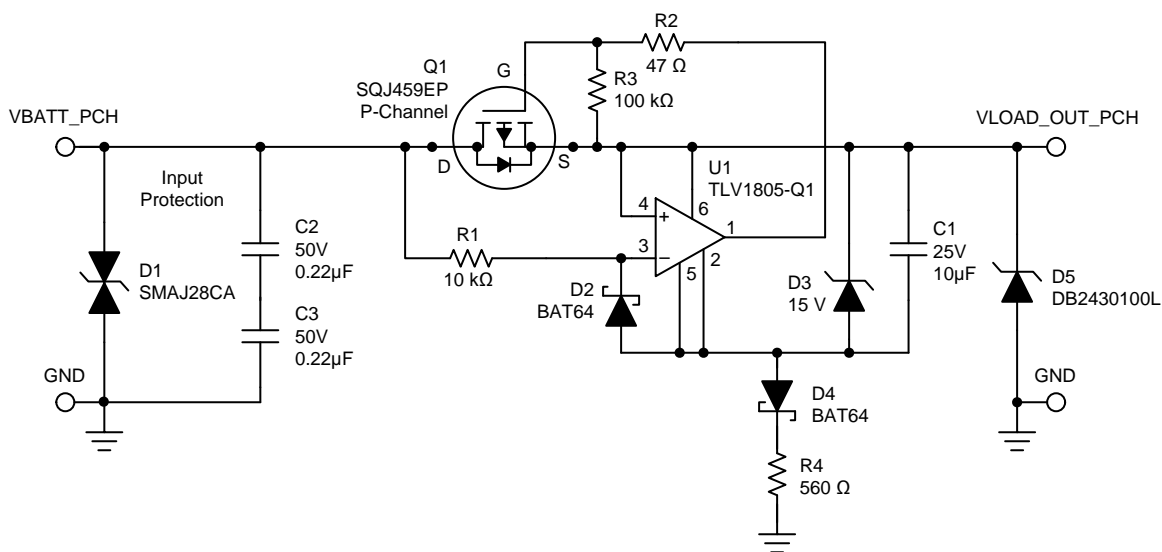

Figure 70. P-Channel Reverse Current Schematic

This design implements a "floating ground" topology, using D3, D4 and R12, to allow for clamping the comparator supply voltage as to not exceed the $V_{GS(MAX)}$ of the MOSFET. During a reverse voltage or supply drop, D4 also prevents C1 from discharging to allow some standby time to keep the comparator powered during the event.

During "normal" forward current operation, the quiescent current of the comparator circuit flows through D4 and R4. D3 provides the clamping during an overvoltage event.

R4 is sized to allow for minimum voltage drop during "normal" operation, but also to allow for dissipation during overvoltage events. R4 will see the battery voltage minus the D3 Zener voltage during an overvoltage event. Since the comparator supply voltage is clamped by D3, the maximum battery voltage is determined by the power dissipated by R4 and the $V_{DS(MAX)}$ of the MOSFET.

R2 limits the gate current should there be any transients and should be a low value to allow the peak currents needed to drive the MOSFET gate capacitance. R3 provides the pull-down needed when the comparator output goes high-Z during power-off to ensure the gate is pulled to zero volts to turn off the MOSFET.

R1 and D2 clamp the input voltage should the V_{BATT} input go below the floating ground Voltage (such as in a battery reversal). A bonus feature is that during a reverse battery voltage condition, D2 and R1 pull the floating ground down towards the negative potential, providing power to the comparator during reverse voltage.

The output clamp diode D5 is used to anchor the output during light or floating loads. At light or no loads, there is a possibility the MOSFET could turn on due to the comparator offset voltage. The diode provides enough of a negative leakage to turn the MOSFET off.

Typical Applications (continued)

If shutdown of the comparator circuit is desired, a transistor or MOSFET switch can be placed between the ground end of R4 and ground. The MOSFET will be in body diode mode when the comparator is disabled.

8.2.6 P-Channel Reverse Current Protection With Overvoltage Protection

The SHDN pin can be utilized to add Overvoltage Protection (OVP) by adding a second MOSFET, zener diode and resistor, as shown in [Figure 71](#).

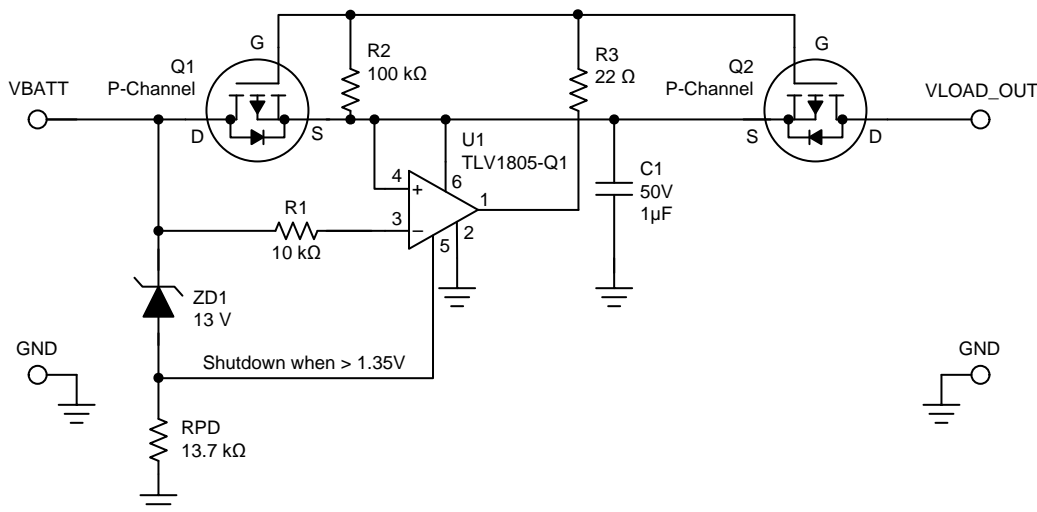

Figure 71. Adding Overvoltage Protection Using SHDN Pin

When the SHDN pin is pulled 1.35 V above V-, the comparator is placed in shutdown. During shutdown, the comparator output goes Hi-Z and R2 pulls the gate and source together to turn off the MOSFET ($V_{GS} = 0$ V).

RPD pulls the SHDN pin low while the Zener diode is not conducting ($< V_Z$). When ZD1 reaches its breakdown voltage and starts conducting, it will pull RPD up to a voltage calculated to place >1.35 V on the shutdown pin.

The Zener diode ZD1 should be chosen so that the breakdown voltage (V_B) is 1.35 V below the desired overvoltage point. The Zener should have low sub-threshold leakage and a sharp knee, such as the low power 1N47xx or BZD series.

The pull-down resistor RPD should be chosen to create 1.35 V at the desired Zener diode current (usually 100uA to 1mA) at the Zener breakdown voltage. Actual resistor value should be verified on the bench due to differences in actual Zener diode threshold voltages.

If a 14.3 V overvoltage trip point (OVP) is desired, the Zener Diode voltage should be 12.95 V. We will choose a 100uA Zener current. The required Zener diode breakdown voltage is determined from:

$$V_B = V_{OV} - 1.35 \text{ V} = 14.3 \text{ V} - 1.35 \text{ V} = 12.95 \text{ V} \quad (9)$$

$$RPD = 1.35 \text{ V} / 100 \text{ } \mu\text{A} = 13.5 \text{ k}\Omega \text{ (13.7k}\Omega \text{ nearest value)} \quad (10)$$

Resistor RPD may be split into two resistors to create a voltage divider if more precise trip points are needed, or a more convenient zener voltage is desired. Series voltage references can also be used if more accuracy is desired. A second resistor in series with the Zener or reference can extend the breakdown voltage.

The maximum voltage allowed on the Shutdown pin is 5.5V, so make sure the highest V_{BATT} voltage does not exceed 5.5 V.

Note that the above circuit, as shown for simplicity, does not protect against reverse voltage. Reverse clamping diodes would be needed on the -IN, SHDN and Load Output. Also make sure V_{BATT} does not exceed the $V_{GS(MAX)}$ of the MOSFET.

Typical Applications (continued)

8.2.7 ORing MOSFET Controller

The previous reverse current circuits may be combined to create an OR'ing supply controller, utilizing either the P-Channel or N-Channel topologies.

For the previous P-Channel circuit, if no negative input voltages are possible, and the input voltage is below the MOSFET's $V_{GS(MAX)}$, then D3, D4 and R4 may be eliminated (the D2 anode, U1 pins 2 and 5, and C1 can be directly grounded).

For the N-Channel circuit, the oscillator drive can be shared between the channels, or eliminated if a higher system voltage is available to provide the higher voltage.

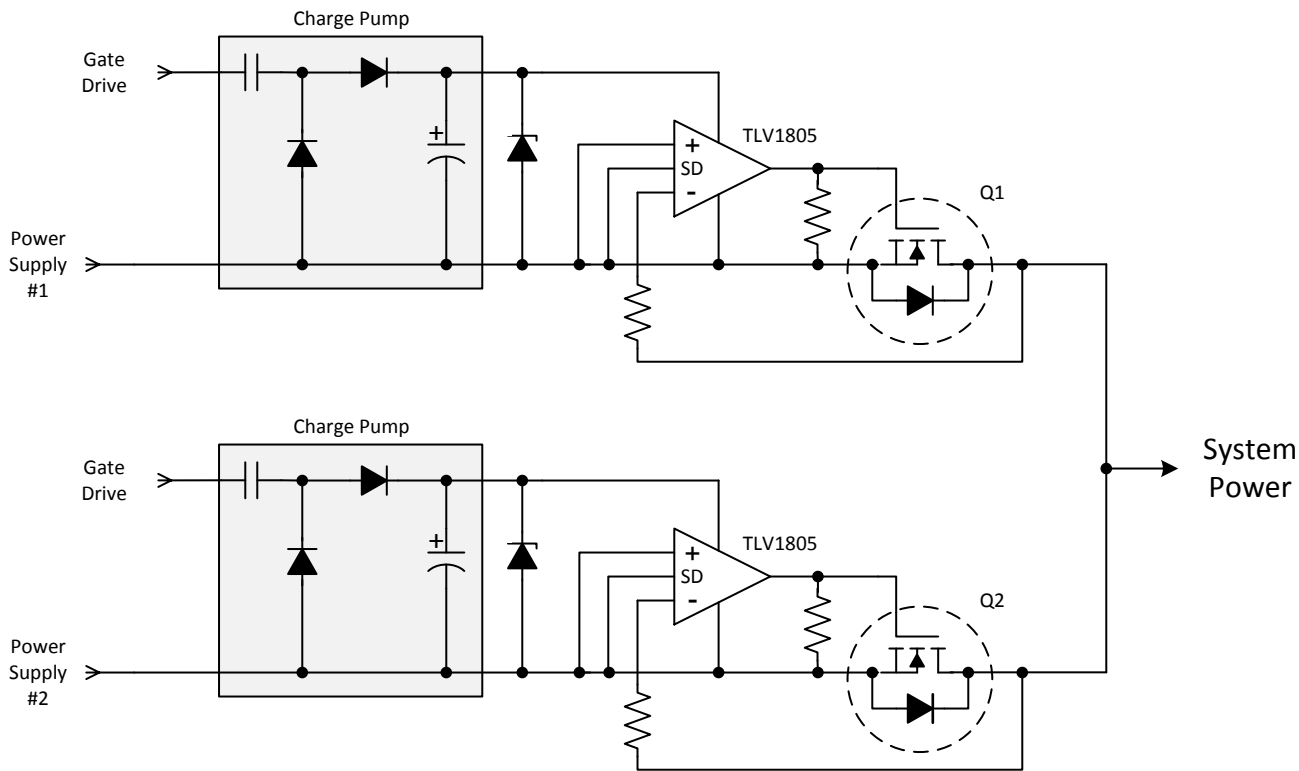

Figure 72. N-Channel OR'ing MOSFET Controller

9 Power Supply Recommendations

The TLV1805 family of devices is specified for operation from 3.3 V to 40 V (± 1.65 to ± 20 V); many specifications apply from -40°C to $+125^{\circ}\text{C}$. Parameters that can exhibit significant variance with regard to operating voltage or temperature are presented in the *Typical Characteristics* section.

CAUTION

Supply voltages larger than 40 V can permanently damage the device; see the *Recommended Operating Conditions* section.

Place 0.1- μF bypass capacitors close to the power-supply pins to reduce errors coupling in from noisy or high-impedance power supplies. For more detailed information on bypass capacitor placement; see the [Layout Guidelines](#) section.

The TLV1805 does not contain reverse battery protection, so applying negative voltage to the supply pins must be avoided. The TLV1805 cannot withstand ISO 16750 type waveforms alone and requires external protection circuitry.

10 Layout

10.1 Layout Guidelines

Comparators are very sensitive to input noise. For best results, maintain the following layout guidelines:

- Use a printed circuit board (PCB) with a good, unbroken low-inductance ground plane. Proper grounding (use of ground plane) helps maintain specified performance of the TLV1805 family of devices.
- To minimize supply noise, place a decoupling capacitor (0.1- μF ceramic, surface-mount capacitor) as close as possible to V_{S} as shown in [Figure 73](#).
- On the inputs and the output, keep lead lengths as short as possible to avoid unwanted parasitic feedback around the comparator. Keep inputs away from the output.
- Solder the device directly to the PCB rather than using a socket.
- Run the ground pin ground trace under the device up to the bypass capacitor, shielding the inputs from the outputs.

10.2 Layout Example

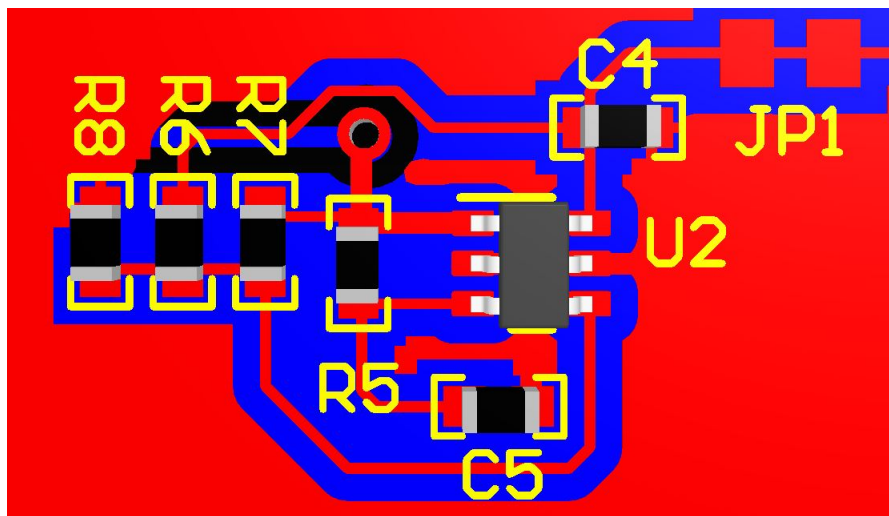

Figure 73. Oscillator Circuit Layout Example

11 Device and Documentation Support

11.1 Documentation Support

11.1.1 Related Documentation

[Precision Design, Comparator with Hysteresis Reference Design— TIDU020](#)

[Reference Design, Window Comparator Reference Design— TIPD178](#)

[EVM Users Guide, TLV1805-Q1 Reverse Current Evaluation Module Users Guide— SNOU158](#)

11.2 Receiving Notification of Documentation Updates

To receive notification of documentation updates, navigate to the device product folder on ti.com. In the upper right corner, click on *Alert me* to register and receive a weekly digest of any product information that has changed. For change details, review the revision history included in any revised document.

11.3 Community Resources

The following links connect to TI community resources. Linked contents are provided "AS IS" by the respective contributors. They do not constitute TI specifications and do not necessarily reflect TI's views; see TI's [Terms of Use](#).

TI E2E™ Online Community *TI's Engineer-to-Engineer (E2E) Community*. Created to foster collaboration among engineers. At e2e.ti.com, you can ask questions, share knowledge, explore ideas and help solve problems with fellow engineers.

Design Support *TI's Design Support* Quickly find helpful E2E forums along with design support tools and contact information for technical support.

11.4 Trademarks

E2E is a trademark of Texas Instruments.

11.5 Electrostatic Discharge Caution



This integrated circuit can be damaged by ESD. Texas Instruments recommends that all integrated circuits be handled with appropriate precautions. Failure to observe proper handling and installation procedures can cause damage.

ESD damage can range from subtle performance degradation to complete device failure. Precision integrated circuits may be more susceptible to damage because very small parametric changes could cause the device not to meet its published specifications.

11.6 Glossary

[SLYZ022](#) — *TI Glossary*.

This glossary lists and explains terms, acronyms, and definitions.

12 Mechanical, Packaging, and Orderable Information

The following pages include mechanical packaging and orderable information. This information is the most current data available for the designated devices. This data is subject to change without notice and revision of this document. For browser-based versions of this data sheet, refer to the left-hand navigation.

PACKAGING INFORMATION

Orderable Device	Status (1)	Package Type	Package Drawing	Pins	Package Qty	Eco Plan (2)	Lead/Ball Finish (6)	MSL Peak Temp (3)	Op Temp (°C)	Device Marking (4/5)	Samples
TLV1805DBVR	ACTIVE	SOT-23	DBV	6	3000	Green (RoHS & no Sb/Br)	CU NIPDAU	Level-1-260C-UNLIM	-40 to 125	1UBF	Samples

(1) The marketing status values are defined as follows:

ACTIVE: Product device recommended for new designs.

LIFEBUY: TI has announced that the device will be discontinued, and a lifetime-buy period is in effect.

NRND: Not recommended for new designs. Device is in production to support existing customers, but TI does not recommend using this part in a new design.

PREVIEW: Device has been announced but is not in production. Samples may or may not be available.

OBSOLETE: TI has discontinued the production of the device.

(2) **RoHS:** TI defines "RoHS" to mean semiconductor products that are compliant with the current EU RoHS requirements for all 10 RoHS substances, including the requirement that RoHS substance do not exceed 0.1% by weight in homogeneous materials. Where designed to be soldered at high temperatures, "RoHS" products are suitable for use in specified lead-free processes. TI may reference these types of products as "Pb-Free".

RoHS Exempt: TI defines "RoHS Exempt" to mean products that contain lead but are compliant with EU RoHS pursuant to a specific EU RoHS exemption.

Green: TI defines "Green" to mean the content of Chlorine (Cl) and Bromine (Br) based flame retardants meet JS709B low halogen requirements of <=1000ppm threshold. Antimony trioxide based flame retardants must also meet the <=1000ppm threshold requirement.

(3) MSL, Peak Temp. - The Moisture Sensitivity Level rating according to the JEDEC industry standard classifications, and peak solder temperature.

(4) There may be additional marking, which relates to the logo, the lot trace code information, or the environmental category on the device.

(5) Multiple Device Markings will be inside parentheses. Only one Device Marking contained in parentheses and separated by a "~" will appear on a device. If a line is indented then it is a continuation of the previous line and the two combined represent the entire Device Marking for that device.

(6) Lead/Ball Finish - Orderable Devices may have multiple material finish options. Finish options are separated by a vertical ruled line. Lead/Ball Finish values may wrap to two lines if the finish value exceeds the maximum column width.

Important Information and Disclaimer:The information provided on this page represents TI's knowledge and belief as of the date that it is provided. TI bases its knowledge and belief on information provided by third parties, and makes no representation or warranty as to the accuracy of such information. Efforts are underway to better integrate information from third parties. TI has taken and continues to take reasonable steps to provide representative and accurate information but may not have conducted destructive testing or chemical analysis on incoming materials and chemicals. TI and TI suppliers consider certain information to be proprietary, and thus CAS numbers and other limited information may not be available for release.

In no event shall TI's liability arising out of such information exceed the total purchase price of the TI part(s) at issue in this document sold by TI to Customer on an annual basis.

OTHER QUALIFIED VERSIONS OF TLV1805 :

- Automotive: [TLV1805-Q1](#)

NOTE: Qualified Version Definitions:

- Automotive - Q100 devices qualified for high-reliability automotive applications targeting zero defects

MECHANICAL DATA

DBV (R-PDSO-G6)

PLASTIC SMALL-OUTLINE PACKAGE

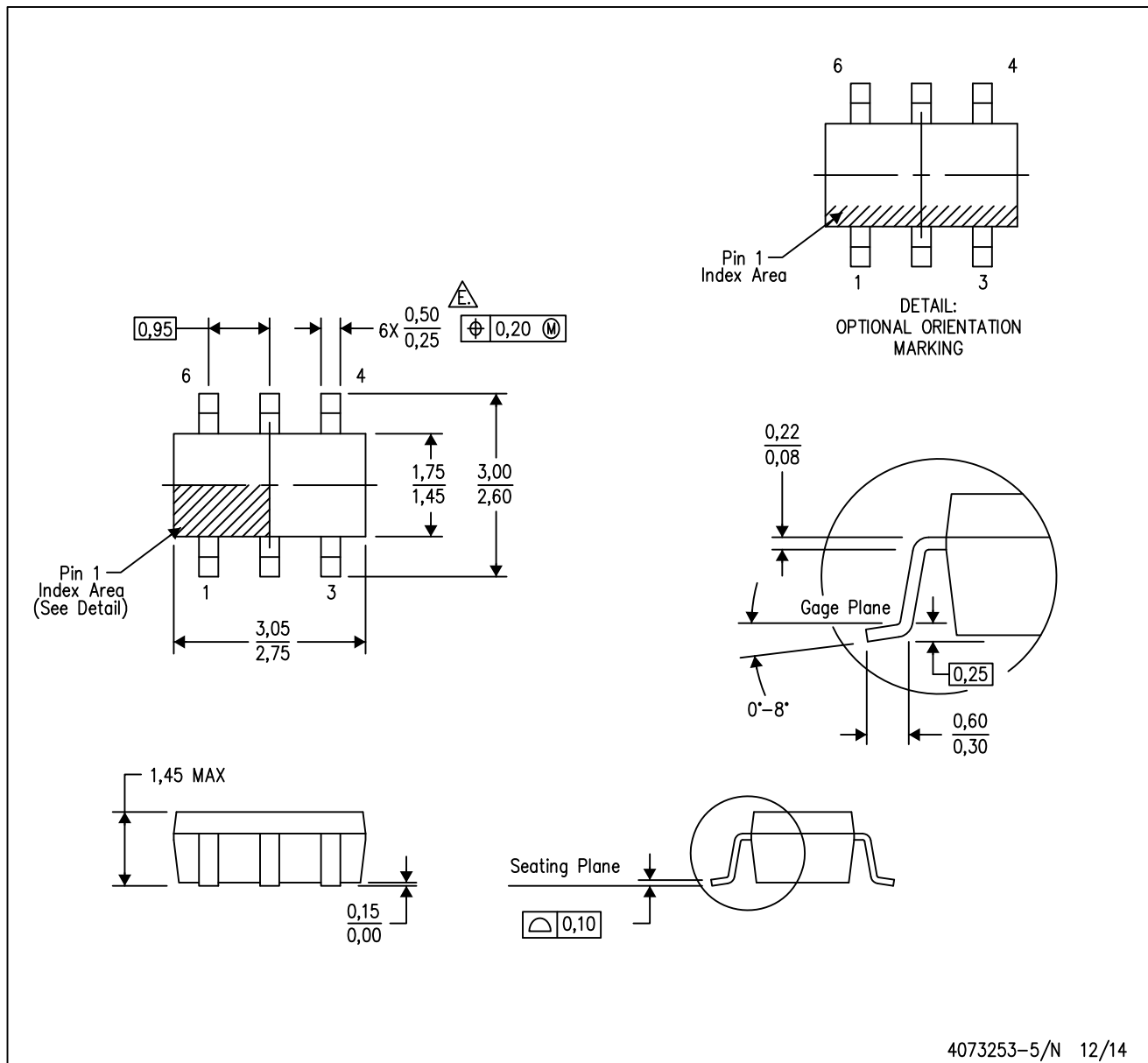

- NOTES:
- All linear dimensions are in millimeters.
 - This drawing is subject to change without notice.
 - Body dimensions do not include mold flash or protrusion. Mold flash and protrusion shall not exceed 0.15 per side.
 - Leads 1,2,3 may be wider than leads 4,5,6 for package orientation.
- ⚠ Falls within JEDEC MO-178 Variation AB, except minimum lead width.

DBV (R-PDSO-G6)

PLASTIC SMALL OUTLINE

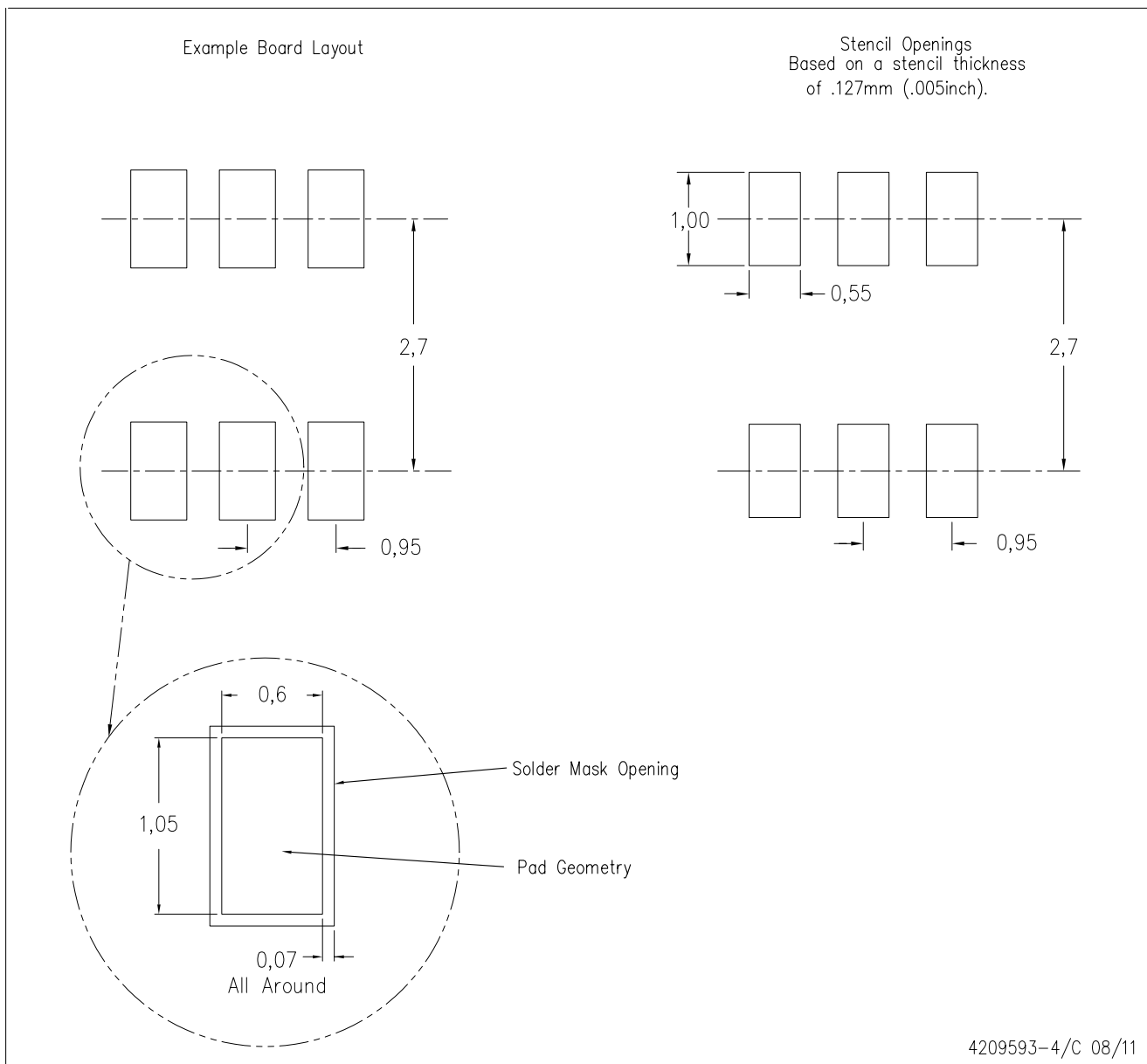

- NOTES:
- A. All linear dimensions are in millimeters.
 - B. This drawing is subject to change without notice.
 - C. Customers should place a note on the circuit board fabrication drawing not to alter the center solder mask defined pad.
 - D. Publication IPC-7351 is recommended for alternate designs.
 - E. Laser cutting apertures with trapezoidal walls and also rounding corners will offer better paste release. Customers should contact their board assembly site for stencil design recommendations. Example stencil design based on a 50% volumetric metal load solder paste. Refer to IPC-7525 for other stencil recommendations.

IMPORTANT NOTICE AND DISCLAIMER

TI PROVIDES TECHNICAL AND RELIABILITY DATA (INCLUDING DATASHEETS), DESIGN RESOURCES (INCLUDING REFERENCE DESIGNS), APPLICATION OR OTHER DESIGN ADVICE, WEB TOOLS, SAFETY INFORMATION, AND OTHER RESOURCES "AS IS" AND WITH ALL FAULTS, AND DISCLAIMS ALL WARRANTIES, EXPRESS AND IMPLIED, INCLUDING WITHOUT LIMITATION ANY IMPLIED WARRANTIES OF MERCHANTABILITY, FITNESS FOR A PARTICULAR PURPOSE OR NON-INFRINGEMENT OF THIRD PARTY INTELLECTUAL PROPERTY RIGHTS.

These resources are intended for skilled developers designing with TI products. You are solely responsible for (1) selecting the appropriate TI products for your application, (2) designing, validating and testing your application, and (3) ensuring your application meets applicable standards, and any other safety, security, or other requirements. These resources are subject to change without notice. TI grants you permission to use these resources only for development of an application that uses the TI products described in the resource. Other reproduction and display of these resources is prohibited. No license is granted to any other TI intellectual property right or to any third party intellectual property right. TI disclaims responsibility for, and you will fully indemnify TI and its representatives against, any claims, damages, costs, losses, and liabilities arising out of your use of these resources.

TI's products are provided subject to TI's Terms of Sale (www.ti.com/legal/termsofsale.html) or other applicable terms available either on ti.com or provided in conjunction with such TI products. TI's provision of these resources does not expand or otherwise alter TI's applicable warranties or warranty disclaimers for TI products.

Mailing Address: Texas Instruments, Post Office Box 655303, Dallas, Texas 75265
Copyright © 2018, Texas Instruments Incorporated