

FEATURES

- Accurate to ± 4 Min/Yr (-40°C to $+85^{\circ}\text{C}$)
- Accurate to ± 1 Min/Yr (0°C to 40°C)
- Battery back up for continuous timekeeping
- V_{BAT} operating voltage: 2.7V to 5.5V with V_{CC} grounded
- V_{CC} operating voltage: 4.5V to 5.5V
- Operating temperature range:
 - 0°C to 70°C (Commercial)
 - -40°C to $+85^{\circ}\text{C}$ (Industrial)
- No calibration required
- Low-power consumption
- Surface mountable using BGA package
 - V_{CC} : C2, C3, D2, D3
 - V_{BAT} : A4, A5, B4, B5
 - 32kHz: C4, C5, D4, D5
 - GND: All Remaining Balls
 - T_{PIN} : A7, A8, B7, B8, C7, C8, D7, D8

ORDERING INFORMATION

DS32kHz/BGA	36-Pin BGA	0°C to $+70^{\circ}\text{C}$
DS32kHz-N/BGA	36-Pin BGA	-40°C to $+85^{\circ}\text{C}$
DS32kHz/DIP	14-Pin DIP	0°C to $+70^{\circ}\text{C}$
DS32kHz-N/DIP	14-Pin DIP	-40°C to $+85^{\circ}\text{C}$

PIN ASSIGNMENT

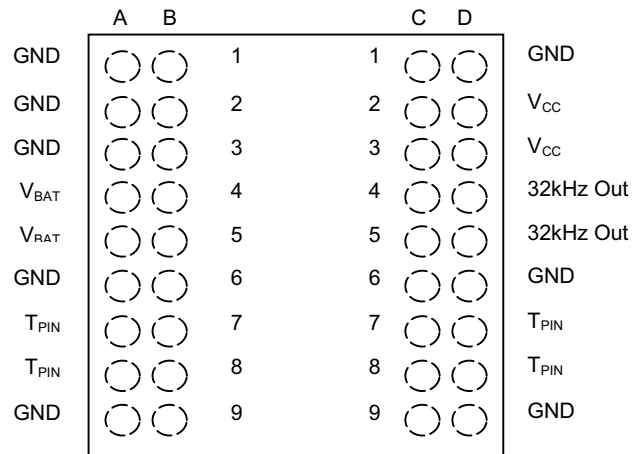

DS32kHz 36-Pin SMD
(Top View)

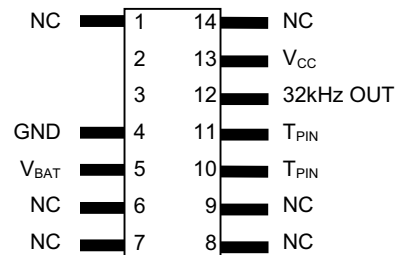

DS32kHz
14-Pin DIP Module (300-mil)

PIN DESCRIPTION

V_{CC}	- Primary Power Supply
V_{BAT}	- +3V Battery Supply
GND	- Ground
NC	- No Connect
T_{PIN}	- Test Pin (Must Be Grounded)

DESCRIPTION

The DS32kHz is a temperature-compensated crystal oscillator (TCXO) with an output frequency of 32.768kHz. This device addresses applications requiring better timekeeping accuracy and may be used to drive the X1 input of most Dallas Semiconductor real-time clocks (RTCs), chipsets, and other ICs containing RTCs. This device is available in commercial and industrial temperature versions, DS32kHz and DS32kHz-N respectively.

below a certain level compared to V_{BAT} , the device switches over to V_{BAT} . (See Figure 1.0.) This mode uses V_{CC} to conserve the battery connected to V_{BAT} while V_{CC} is applied.

In the single-supply mode, V_{CC} is grounded and the unit is powered by V_{BAT} . Current consumption is less than that of V_{CC} , because the comparator circuit is unpowered. (See Figure 2.0.)

POWER SUPPLY CONNECTIONS Figures 1.0 and 2.0

Figure 1.0

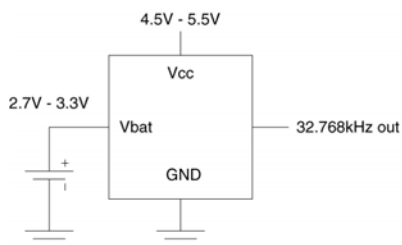

Figure 2.0

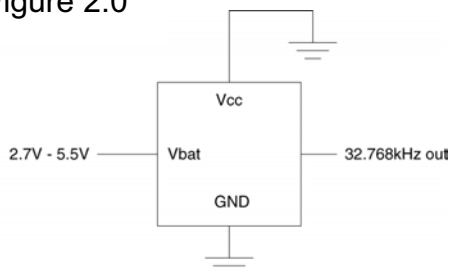

Figure 1.0 shows how the DS32kHz should be connected when using two power supplies. V_{CC} should be between 4.5V and 5.5V and V_{BAT} should be between 2.7V and 3.3V. Figure 2.0 shows how the DS32kHz can be used when only a single-supply system is available. V_{CC} should be grounded and V_{BAT} should then be held between 2.7V and 5.5V. The V_{BAT} pin should be connected directly to a battery using no external components.

DS32kHz CONNECTIONS Figures 3.0 and 4.0

Figure 3.0

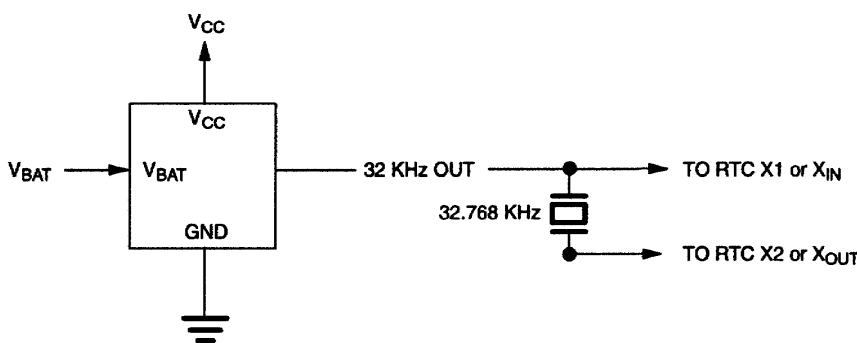

Figure 4.0

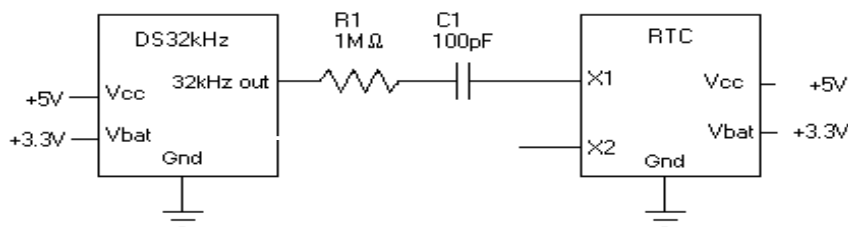

Figure 3.0 illustrates how a standard 32.768kHz crystal and the DS32kHz should be connected to address the interchangeable option. Using this connection scheme and the recommended layout provides a solution, which requires no hardware modifications. Only one device should be used at a time, and both layouts should be located very close together if the recommended layout is not used.

The DS32kHz I_{CC} and I_{BAT} currents are specified with no output loads. Many RTC oscillator circuits use a quartz crystal or resonator. Driving the oscillator circuit with the rail-to-rail output of the DS32kHz may increase the I_{CC} and I_{BAT} currents significantly and increase the current consumption of the RTC as well. Figure 4 shows one recommended circuit that can be used to reduce the current consumption of a DS32kHz and an RTC. The values of R1 and C1 will vary depending on the RTC used. However, values of 1.0M Ω and 100pF are recommended as a starting point.

RELATED APPLICATION NOTES

Application Note 58 – Crystal Considerations with Dallas Real-Time Clocks

Application Note 701 – Using the DS32kHz with Dallas RTCs

RECOMMENDED DC OPERATING CONDITIONS (-40°C to +85°C)

PARAMETER	SYMBOL	MIN	TYP	MAX	UNITS	NOTES
Power Supply Voltage	V_{CC}	4.5	5.0	5.5	V	
Battery Voltage	V_{BAT}	2.7	3.0	3.3, 5.5	V	1

DC ELECTRICAL CHARACTERISTICS (Over the operating range*)

PARAMETER	SYMBOL	MIN	TYP	MAX	UNITS	NOTES
Active Supply Current	I_{CC}		150	180	μ A	2,5
Active Battery Current ($V_{CC} = 0V$, $V_{BAT} = 3.3V$)	I_{BAT}		1	4	μ A	2,3,5
High Output Voltage (V_{CC}) ($I_{OH} = -1.0mA$)	V_{OH}	2.4			V	
Low Output Voltage ($I_{OL} = 2.1mA$)	V_{OL}			0.4	V	
Battery Switch Voltage	V_{SW}		V_{BAT}		V	
High Output Voltage (V_{BAT}) ($I_{OH} = -0.1mA$)	V_{OH}	2.4			V	

*Unless otherwise specified.

ABSOLUTE MAXIMUM RATINGS*

Voltage on Any Pin Relative to Ground	-3.0V to +7.0V
Operating Temperature	0°C to 70°C (Commercial) -40°C to +85°C (Industrial)
Storage Temperature	-40°C to +85°C
Soldering Temperature	See J-STD-020A specification. (Two times max.)

* This is a stress rating only and functional operation of the device at these or any other conditions above those indicated in the operation sections of this specification is not implied. Exposure to absolute maximum rating conditions for extended periods of time may affect reliability.

AC TIMING CHARACTERISTICS (Over the operating range*)

PARAMETER	SYMBOL	MIN	TYP	MAX	UNITS	NOTES
Output Frequency	f_{OUT}		32.768		kHz	
Frequency Stability vs Temp (0°C to 40°C)	$\Delta f/f_O$	-3.0	+1	+2.0	ppm	
(-40°C to +85°C)		-7.5		+7.5		
Duty Cycle	T_W/T	45	50	55	%	
Cycle Time	t_{CYC}		30.518		μs	4
High/Low Time	t_H/t_L		15.06		μs	4
Rise Time	t_R		200		ns	4
Fall Time	t_F		60		ns	4
Oscillator Start-Up Time	t_{OSC}		1		sec	4
Frequency Stability vs Operating Voltage (3.3V Nom)	$\Delta f/V$		± 1.0		ppm/v	
Crystal Aging	$\Delta f/f_O$		± 1.0		ppm/yr	6

*Unless otherwise specified.

NOTES:

1. V_{BAT} must be no greater than 3.3V when the device is used in the dual-supply operating modes.
2. Typical values are at +25°C and 5.0V V_{CC} unless otherwise indicated.
3. This current is the active mode current sourced from the backup supply/battery.
4. These parameters are measured using a 15pF load.
5. These parameters are measured under no load conditions.
6. After reflow.

DS32kHz OUTPUT WAVEFORM

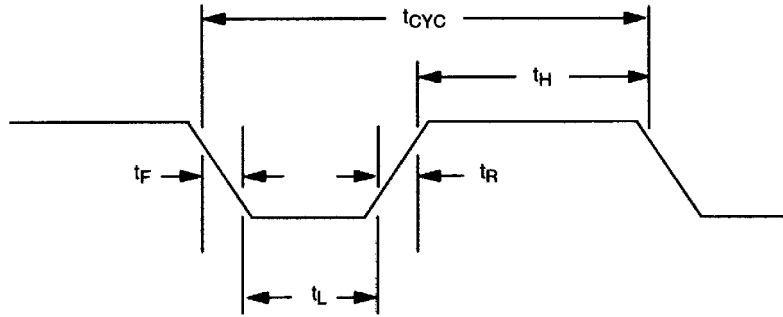

MECHANICAL DIMENSIONS

PKG	36-PIN BALL GRID	
DIM	MIN	MAX
A (in)	.395	.405
B (in)	.445	.455
C (in)	.022	.028
D (in)	.047	.053
E (in)	.047	.053
F (in)	.347	.353
G (in)	.170	.190
H (in)	.020	.030

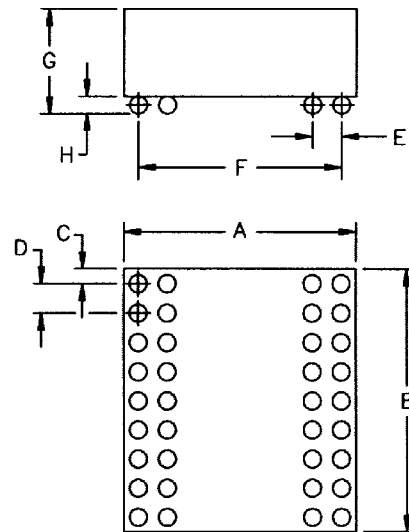

RECOMMENDED LAND PATTERN LAYOUT (36-Pin BGA)

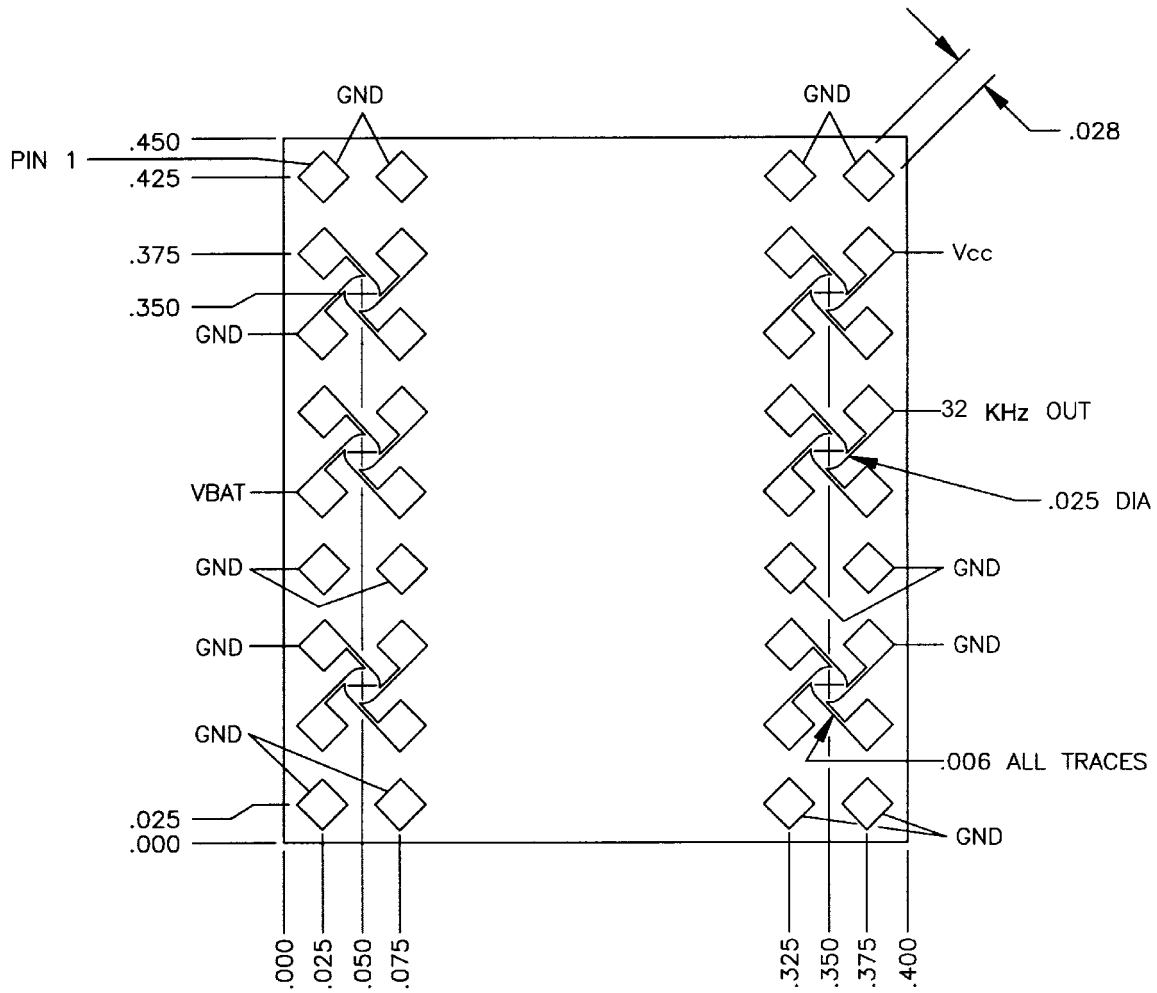

DS32kHz 14-PIN DIP MODULE

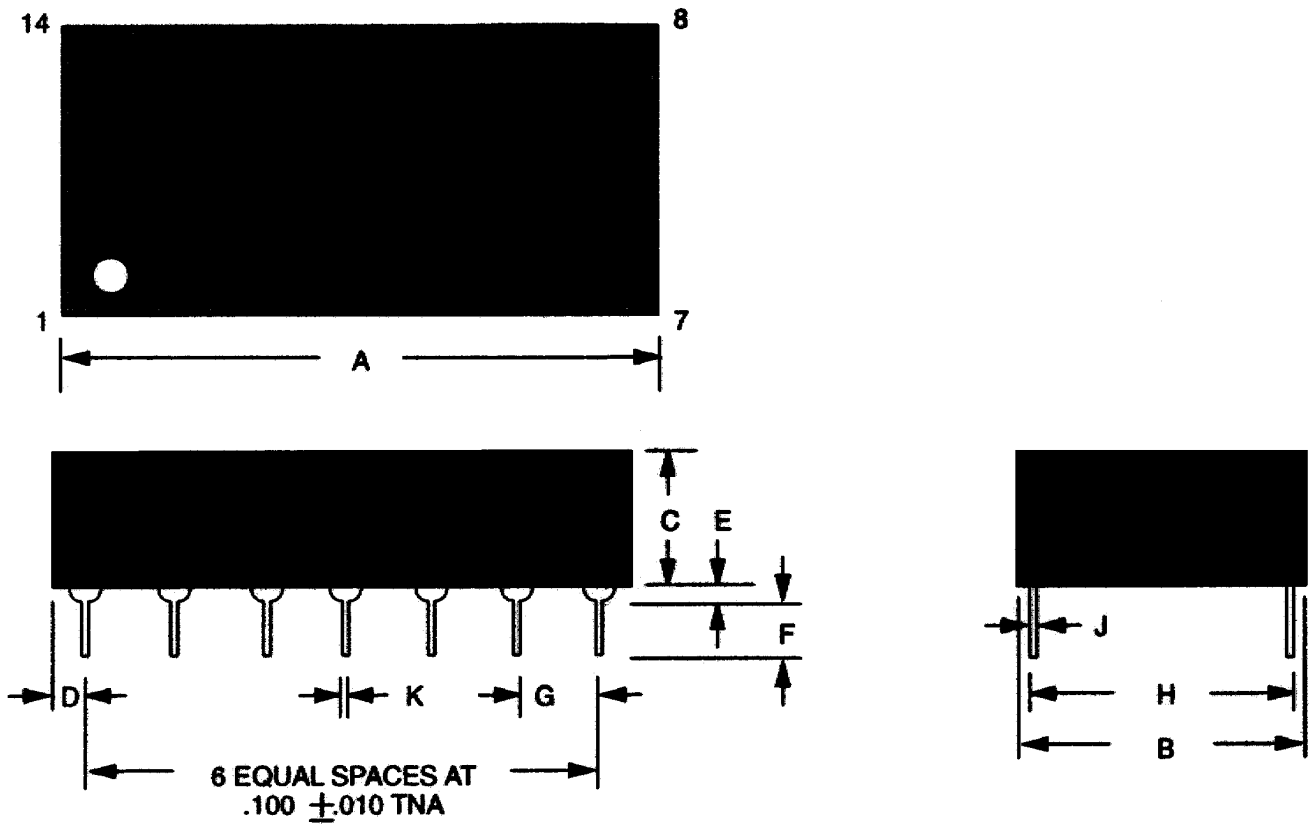

PKG DIM	14-PIN DIP	
	MIN	MAX
A IN.	0.825	0.840
B IN.	0.420	0.440
C IN.	0.235	0.260
D IN.	0.100	0.130
E IN.	0.015	0.030
F IN.	0.110	0.140
G IN.	0.090	0.110
H IN.	0.290	0.330
J IN.	0.008	0.012
K IN.	0.015	0.021

Note: Pins 2, 3 are missing by design.