

NO	DESCRIPTION	MATERIAL	Q'TY	FINISH	REMARK
1	NUT	BRASS	1	NICKEL	N-0030-N
2	RUBBER	SI RUBBER	1	RUBBER	RU-0029
3	BODY 1	BRASS	1	NICKEL	B-N0638-N
4	INSULATION 1	TEFLON	1	TEFLON	I-0486T
5	BODY 2	BRASS	1	NICKEL	B-N0639-N
6	WASHER	PH.BRONZE	1	NICKEL	W-0014-N
7	RUBBER	SI RUBBER	1	RUBBER	RU-0007
8	PIN	BRASS	1	GOLD	P-N0698-G
9	BODY 3	BRASS	1	NICKEL	B-N0032-N
10	BODY 4	BRASS	1	NICKEL	B-N0033-N
11	WASHER	BRASS	1	NICKEL	W-0053-N

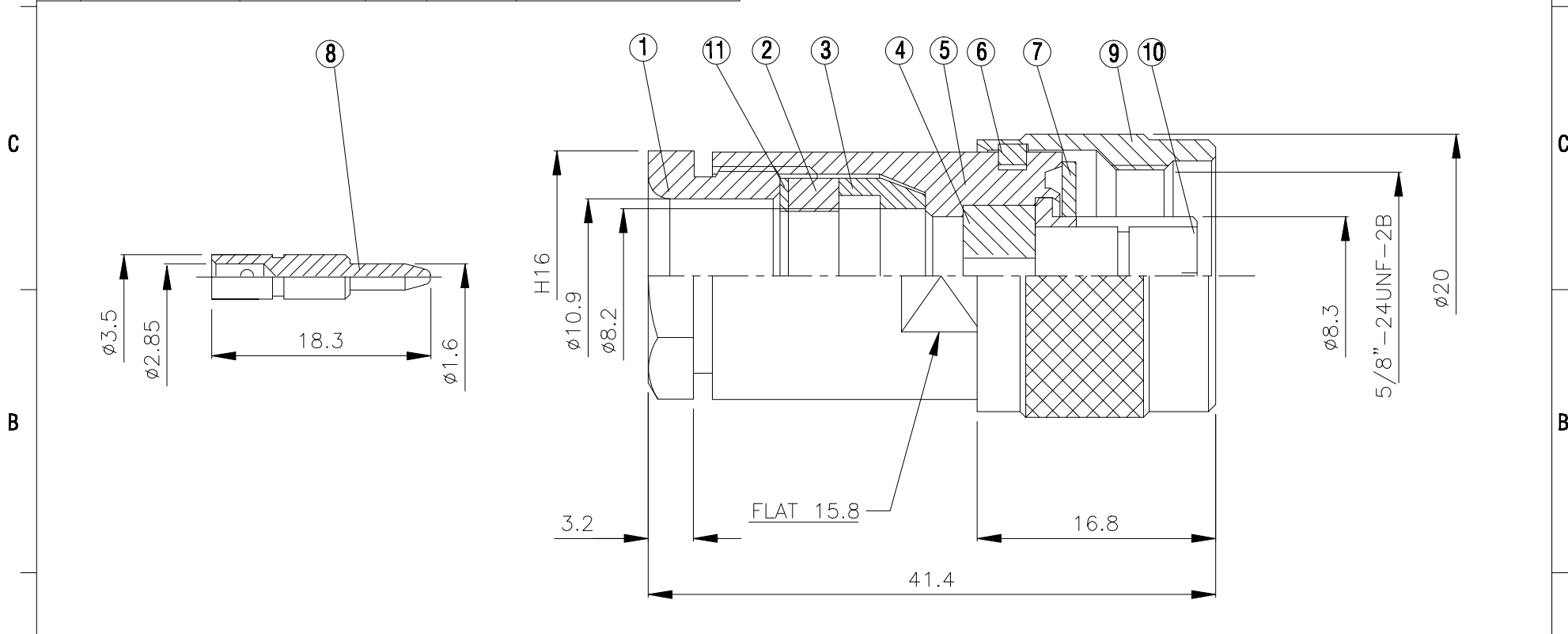
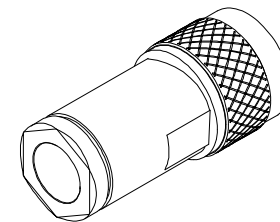

	HUS-TSAN GROUP CO., LTD.		DRAWN	MARY	DATE	94.09.15	DIMENSIONS ARE IN MILLIMETERS		REVISION	
	P.O.BOX 40-76.TAINAN.TAIWAN,R.O.C.		CHECKED		DATE	97.07.04	UNLESS OTHERWISE SPECIFIED TOLERANCE		DESCRIPTION	ENGINEER
	TITLE N MALE CLAMP FOR LMR-400		Q.A.		DATE		0.5-5=±0.2	120-315=±1		
	PART NO. N-01S-TGN		APPROVAL		DATE		5-30=±0.4	315-1000=±1.6		
	DRAWING NO. N-01S-TGN		REVISION		DATE		30-120=±0.6	1000-2000=±2.4		
						SCALE	4:1	SIZE	A	

4

3

2

1