

NO	DESCRIPTION	MATERIAL	Q'TY	FINISH	REMARK
1	SHELL	BRASS	1	GOLD	B-SMA0043-G
2	GASKET	SI RUBBER	1	RUBBER	RU-0008
3	WASHER	SUS	1	PASSIVATED	W-0012
4	INSULATION	TEFLON	1	TEFLON	I-0138T
5	PIN	BRASS	1	GOLD	P-SMA0065-G
6	BODY	BRASS	1	GOLD	B-SMA0155-G
7	INSULATION	TEFLON	1	TEFLON	I-0136T
8	WASHER	BRASS	1	GOLD	W-0023-G
9	BODY	BRASS	1	GOLD	B-SMA0154-G
10	RING	BRASS	1	GOLD	R-0002-G

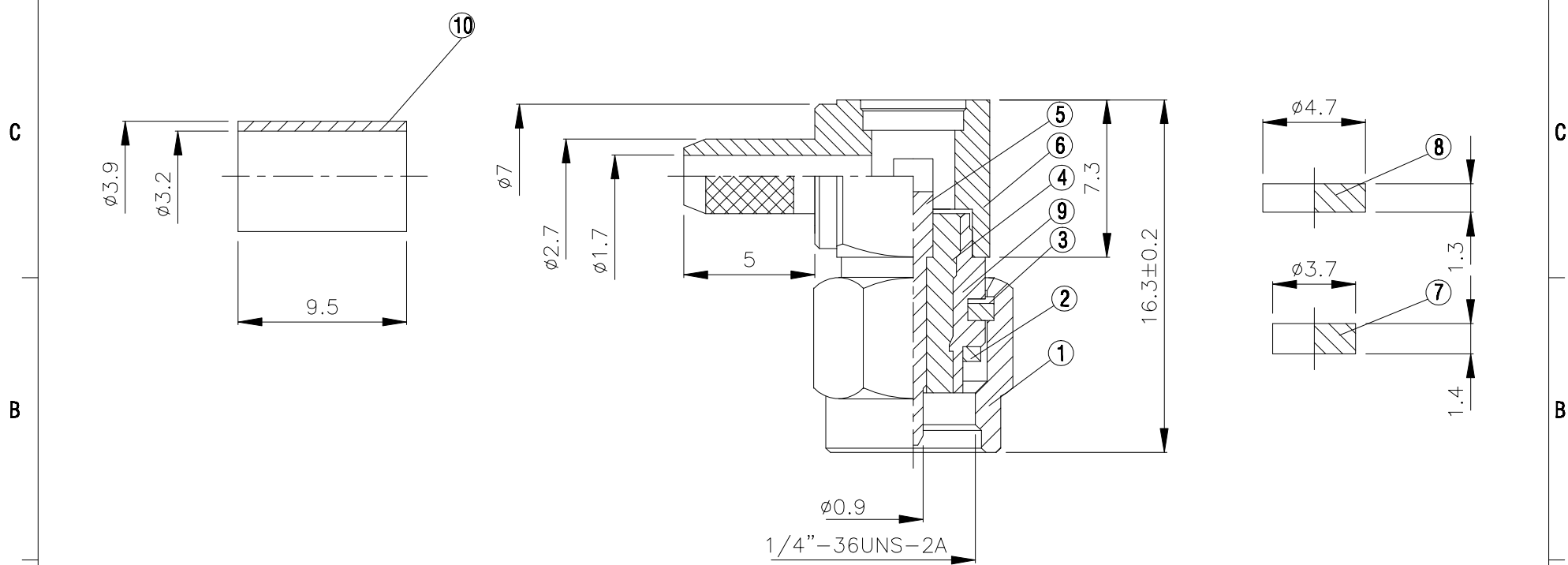
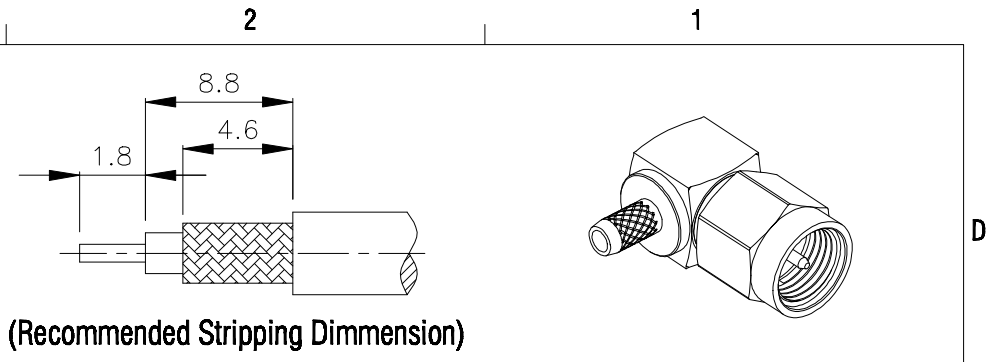

Nominal voltage: 250V

	HUS-TSAN GROUP CO., LTD. P.O.BOX 40-76.TAINAN.TAIWAN,R.O.C.		DRAWN MARY DATE 107.06.03	DIMENSIONS ARE IN MILLIMETERS UNLESS OTHERWISE SPECIFIED TOLERANCE		REVISION		
	TITLE SMA MALE CRIMP FOR RG 174U Series SMA-02		CHECKED 徐燦霖 DATE 107.06.03	0.5-5 = ± 0.2 120-315 = ± 1 5-30 = ± 0.4 315-1000 = ± 1.6 30-120 = ± 0.6 1000-2000 = ± 2.4		DESCRIPTION	ENGINEER	
	PART NO. SMA-02LV1-TGG		Q.A. 莊千慧 DATE 107.06.03	SCALE	4:1	SIZE	A	
	DRAWING NO. SMA 02LV1 TGG		APPROVAL 徐燦霖 DATE 107.06.03	REVISION				
			REVISION DATE					