

74LS245 Transceiver

Octal Transceiver (3-State)
Product Specification

Logic Products

FEATURES

- Octal bidirectional bus interface
- 3-State buffer outputs
- PNP inputs for reduced loading
- Hysteresis on all Data inputs

DESCRIPTION

The 'LS245 is an octal transceiver featuring non-inverting 3-State bus compatible outputs in both send and receive directions. The outputs are all capable of sinking 24mA and sourcing up to 15mA, producing very good capacitive drive characteristics. The device features a Chip Enable (CE) input for easy cascading and a Send/Receive (S/R) input for direction control. All data inputs have hysteresis built in to minimize AC noise effects.

TYPE	TYPICAL PROPAGATION DELAY	TYPICAL SUPPLY CURRENT (TOTAL)
74LS245	8ns	58mA

ORDERING CODE

PACKAGES	COMMERCIAL RANGE $V_{CC} = 5V \pm 5\%$; $T_A = 0^\circ C$ to $+70^\circ C$
Plastic DIP	N74LS245N
Plastic SOL-20	N74LS245D

NOTE:

For information regarding devices processed to Military Specifications, see the Signetics Military Products Data Manual.

INPUT AND OUTPUT LOADING AND FAN-OUT TABLE

PINS	DESCRIPTION	74LS
All	Inputs	1LSul
All	Outputs	30LSul

NOTE:

Where a 74LS unit load (LSul) is $20\mu A$ I_{IH} and $-0.4mA$ I_{IL} .

PIN CONFIGURATION

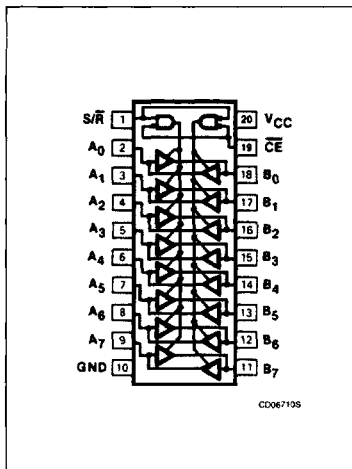

LOGIC SYMBOL

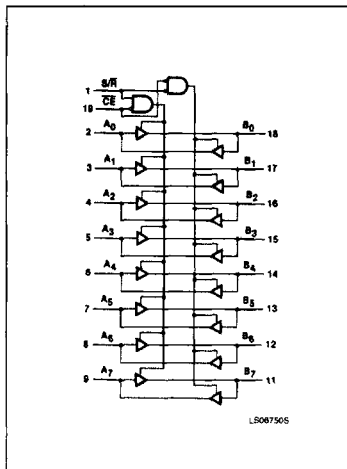

LOGIC SYMBOL (IEEE/IEC)

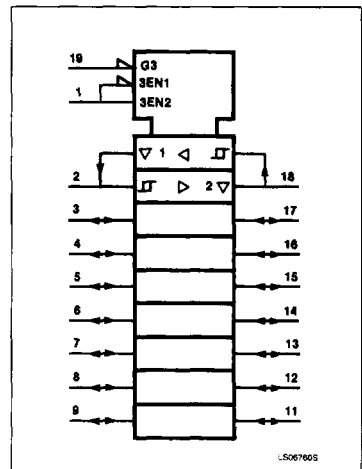

Transceiver

74LS245

FUNCTION TABLE

INPUTS		INPUTS/OUTPUTS	
CE	S/R	A _n	B _n
L	L	A = B	INPUTS
L	H	INPUT	B = A
H	X	(Z)	(Z)

H = HIGH voltage level

L = LOW voltage level

X = Don't care

(Z) = HIGH impedance "off" state

ABSOLUTE MAXIMUM RATINGS (Over operating free-air temperature range unless otherwise noted.)

PARAMETER		74LS	UNIT
V _{CC}	Supply voltage	7.0	V
V _{IN}	Input voltage	-0.5 to +7.0	V
I _{IN}	Input current	-30 to +1	mA
V _{OUT}	Voltage applied to output in HIGH output state	-0.5 to +V _{CC}	V
T _A	Operating free-air temperature range	0 to 70	°C

NOTE

V_{IN} limited to 5.5V on A and B inputs only.

RECOMMENDED OPERATING CONDITIONS

PARAMETER	74LS			UNIT
	Min	Nom	Max	
V _{CC}	4.75	5.0	5.25	V
V _{IH}	2.0			V
V _{IL}			+0.8	V
I _{IK}			-18	mA
I _{OH}			-15	mA
I _{OL}			24	mA
T _A	0		70	°C

Transceiver

74LS245

DC ELECTRICAL CHARACTERISTICS (Over recommended operating free-air temperature range unless otherwise noted.)

PARAMETER		TEST CONDITIONS ¹		74LS245			UNIT
				Min	Typ ²	Max	
ΔV_T	Hysteresis ($V_{T+} - V_{T-}$)	$V_{CC} = \text{MIN}$		0.2	0.4		V
V_{OH}	HIGH-level output voltage	$V_{CC} = \text{MIN}$, $V_{IH} = \text{MIN}$, $V_L = \text{MAX}$	$I_{OH} = \text{MAX}$	2.0			V
			$I_{OH} = -3\text{mA}$	2.4	3.4		V
V_{OL}	LOW-level output voltage	$V_{CC} = \text{MIN}$, $V_{IH} = \text{MIN}$, $V_{IL} = \text{MAX}$	$I_{OL} = \text{MAX}$			0.5	V
			$I_{OL} = 12\text{mA}$ (74LS)			0.4	V
V_{IK}	Input clamp voltage	$V_{CC} = \text{MIN}$, $I_I = I_{IK}$				-1.5	V
I_{OZH}	Off-state output current, HIGH-level voltage applied	$V_{CC} = \text{MAX}$, $V_O = 2.7\text{V}$, $\overline{CE} = 2.0\text{V}$				20	μA
I_{OZL}	Off-state output current, LOW-level voltage applied	$V_{CC} = \text{MAX}$, $V_O = 0.4\text{V}$, $\overline{CE} = 2.0\text{V}$				-200	μA
I_I	Input current at maximum input voltage	$V_{CC} = \text{MAX}$	$V_I = 5.5\text{V}$	A, B inputs		0.1	mA
			$V_I = 7.0\text{V}$	S/ \overline{R} , \overline{CE} inputs		0.1	mA
I_{IH}	HIGH-level input current	$V_{CC} = \text{MAX}$, $V_I = 2.7\text{V}$				20	μA
I_{IL}	LOW-level input current	$V_{CC} = \text{MAX}$, $V_I = 0.4\text{V}$				-0.2	mA
I_{OS}	Short-circuit output current ³	$V_{CC} = \text{MAX}$		-40		-130	mA
I_{CC}	Supply current ⁴ (total)	$V_{CC} = \text{MAX}$	I_{OCH} Outputs HIGH		48	70	mA
			I_{OCL} Outputs LOW		62	90	mA
			I_{OZZ} Outputs OFF		64	95	mA

NOTES:

- For conditions shown as MIN or MAX, use the appropriate value specified under recommended operating conditions for the applicable type.
- All typical values are at $V_{CC} = 5\text{V}$, $T_A = 25^\circ\text{C}$.
- I_{OS} is tested with $V_{OUT} = +0.5\text{V}$ and $V_{CC} = V_{CC\text{ MAX}} + 0.5\text{V}$. Not more than one output should be shorted at a time and duration of the short circuit should not exceed one second.
- Measure I_{CC} with outputs open.

AC ELECTRICAL CHARACTERISTICS $T_A = 25^\circ\text{C}$, $V_{CC} = 5.0\text{V}$

PARAMETER		TEST CONDITIONS		74LS		UNIT
				$C_L = 4\text{pF}$, $R_L = 867\Omega$		
				Min	Max	
t_{PLH}	Propagation delay	Waveform 1			12	ns
t_{PHL}	Propagation delay	Waveform 1			12	ns
t_{PZH}	Enable to HIGH	Waveform 2			40	ns
t_{PZL}	Enable to LOW	Waveform 3			40	ns
t_{PHZ}	Disable from HIGH	Waveform 2, $C_L = 5\text{pF}$			25	ns
t_{PLZ}	Disable from LOW	Waveform 3, $C_L = 5\text{pF}$			25	ns

Transceiver

74LS245

AC WAVEFORMS

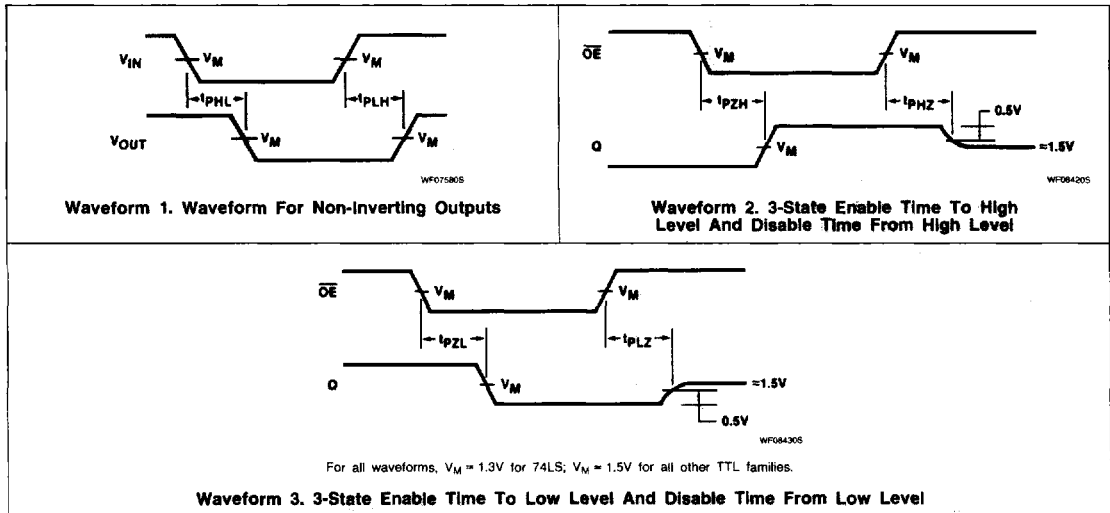

TEST CIRCUITS AND WAVEFORMS

