

**Size 1210 (EIA) or 3225 (IEC)**  
**Rated inductance 0,010 to 10  $\mu$ H**  
**Rated current 90 to 700 mA**



### Construction

- Ceramic or ferrite core
- Single-layer winding fixed by glue
- US-welded winding
- Without encapsulation

### Features

- Low height
- High  $Q$  factor
- High resonance frequency
- Suitable for reflow (IR and vapor phase) and wave soldering

### Applications

- Filtering of supply voltages, coupling, decoupling
- Antenna systems
- Automotive electronics
- Telecommunications

### Terminals

- Silver-plated
- 1–2  $\mu$ m Cu, 4–6  $\mu$ m Ag
- Base material CuSn6
- Suitable for soldering and conductive adhesion
- No leaching during wave soldering

### Marking

No marking on component

Minimum data on reel:

Manufacturer, part number, ordering code,  
 $L$  value and tolerance of  $L$  value,  
quantity, date of packing

### Delivery mode

8-mm blister tape, wound on 180-mm or 330-mm  $\varnothing$  reel

For details on taping, packing and packing units [see page 153](#)

**General technical data**

Rated inductance $L_R$	Measured with impedance analyzer HP 4194A at frequency $f_L$
Q factor $Q_{\min}$	Measured with impedance analyzer HP 4194A/HP 4291A at frequency $f_Q$
Rated current $I_R$	Maximum permissible dc with inductance decrease $\Delta L/L_0 \leq 10\%$ and temperature increase of $\leq 20\text{ K}$ at rated temperature of $85^\circ\text{C}$
Self-resonance frequency $f_{\text{res, min}}$	Measured with network analyzer HP 8753
DC resistance $R_{\max}$	Measured at $20^\circ\text{C}$ ambient temperature, measuring current $< I_R$
Climatic category	In accordance with IEC 60068-1 55/125/56 ( $-55^\circ\text{C}/+125^\circ\text{C}/56$ days damp heat test)
Solderability	In accordance with IEC 60062-2-58 ( $215 \pm 3$ ) $^\circ\text{C}$ , ( $3 \pm 0,3$ ) s Wetting of soldering area: $\geq 95\%$
Resistance to soldering heat	In accordance with IEC 60068-2-20 $260^\circ\text{C}$ , 10 s $\Delta L/L \leq \pm 3\%$
Permissible PCB bending	2 mm (100 mm long standard PCB)
Weight	Approx. 40 mg

**Dimensional drawing**

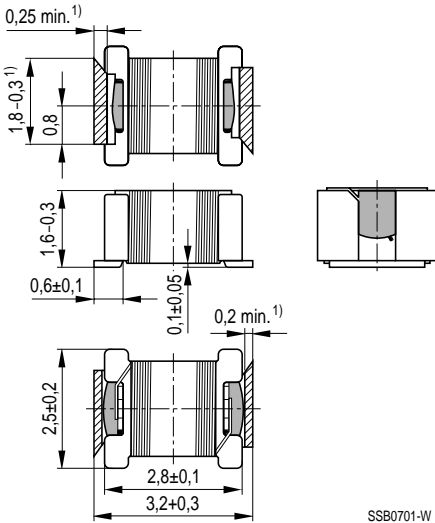

**Layout recommendation**

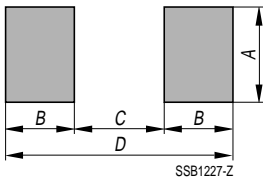

Dimensions (mm)	A	B	C	D
Wave soldering	2,3	1,60	2,1	5,3
Reflow soldering	2,7	1,15	2,1	4,4

1) Soldering area, silver-plated

**Characteristics and ordering codes**

$L_R$ $\mu\text{H}$	Tolerance <sup>1)</sup>	$f_L$ MHz	$Q_{\min}$	$f_Q$ MHz	$I_R$ mA	$R_{\max}$ $\Omega$	$f_{\text{res, min}}$ MHz	Ordering code <sup>2)</sup> ( $\varnothing$ 180-mm reel)
Core material: ceramics								
0,010	$\pm 20\%$ $\triangleq M$	10	25	100	700	0,10	4000	B82412-A3100-M
0,012		10	25	100	700	0,10	3500	B82412-A3120-M
0,015		10	25	100	640	0,12	3000	B82412-A3150-M
0,018		10	30	100	640	0,12	2700	B82412-A3180-M
0,022	$\pm 5\%$ $\triangleq J$	10	30	100	600	0,12	2400	B82412-A3220-+
0,027		10	20	50	600	0,15	2200	B82412-A3270-+
0,033	$\pm 10\%$ $\triangleq K$	10	25	50	540	0,17	2000	B82412-A3330-+
0,039		10	25	50	500	0,18	1700	B82412-A3390-+
0,047		10	25	50	470	0,22	1600	B82412-A3470-+
0,056		10	30	50	460	0,23	1400	B82412-A3560-+
0,068		10	30	50	440	0,25	1350	B82412-A3680-+
0,082		10	30	50	430	0,27	1100	B82412-A3820-+
0,10		10	30	50	400	0,30	1000	B82412-A3101-+
0,12		1	25	30	380	0,35	900	B82412-A3121-+
0,15		1	25	30	370	0,36	820	B82412-A3151-+
0,18		1	25	30	340	0,42	700	B82412-A3181-+
0,22	1	25	30	320	0,48	630	B82412-A3221-+	
0,27	1	30	30	300	0,55	570	B82412-A3271-+	
0,33	1	30	30	280	0,65	550	B82412-A3331-+	
0,39	1	30	30	260	0,75	500	B82412-A3391-+	
0,47	1	30	30	225	1,00	450	B82412-A3471-+	
0,56	1	30	30	200	1,20	430	B82412-A3561-+	
0,68	1	30	30	180	1,40	400	B82412-A3681-+	
0,82	1	30	30	150	2,00	380	B82412-A3821-+	

1) Closer tolerances and special versions upon request.

2) Replace the + by the code letter for the required inductance tolerance.

For reel size  $\varnothing$  330 mm append code number »8«. Example: B82412-A3100-M8

**Characteristics and ordering codes (continued)**

$L_R$ $\mu\text{H}$	Tolerance <sup>1)</sup>	$f_L$ MHz	$Q_{\min}$	$f_Q$ MHz	$I_R$ mA	$R_{\max}$ $\Omega$	$f_{\text{res, min}}$ MHz	Ordering code <sup>2)</sup> ( $\varnothing$ 180-mm reel)
Core material: ferrite								
1,0	$\pm 5\%$	1	30	7,96	330	0,45	300	B82412-A1102-+
1,2	$\triangleq J$	1	30	7,96	310	0,50	260	B82412-A1122-+
1,5	$\pm 10\%$	1	30	7,96	300	0,55	240	B82412-A1152-+
1,8	$\triangleq K$	1	30	7,96	290	0,60	220	B82412-A1182-+
2,2		1	30	7,96	270	0,65	200	B82412-A1222-+
2,7		1	30	7,96	220	1,05	180	B82412-A1272-+
3,3		1	30	7,96	200	1,10	160	B82412-A1332-+
3,9		1	30	7,96	190	1,35	150	B82412-A1392-+
4,7		1	35	7,96	160	1,80	140	B82412-A1472-+
5,6		1	35	7,96	140	2,70	125	B82412-A1562-+
6,8		1	35	7,96	120	3,50	115	B82412-A1682-+
8,2		1	35	7,96	110	3,80	100	B82412-A1822-+
10		1	35	7,96	90	5,50	95	B82412-A1103-+

1) Closer tolerances and special versions upon request.

2) Replace the + by the code letter for the required inductance tolerance.

For reel size  $\varnothing$  330 mm append code number »8«. Example: B82412-A1102-K8

Impedance  $|Z|$   
versus frequency  $f$   
measured with impedance analyzer  
HP 4291A

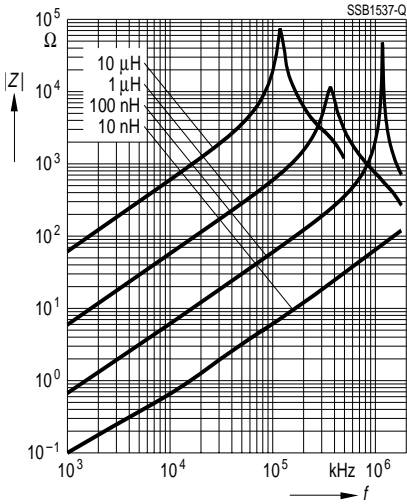

Inductance  $L$   
versus dc load current  $I_{DC}$   
measured with LCR meter  
HP 4275A

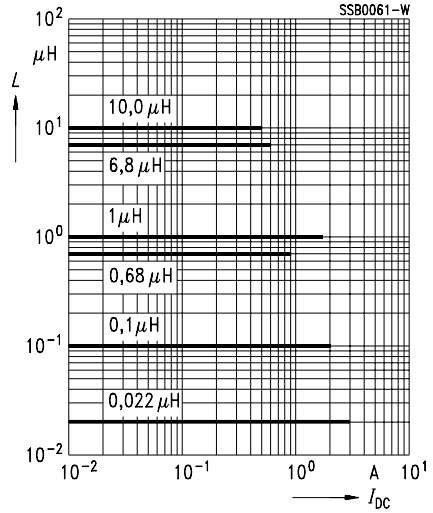

Q factor versus frequency  $f$   
measured with impedance analyzer  
HP 4194A / HP 4291A

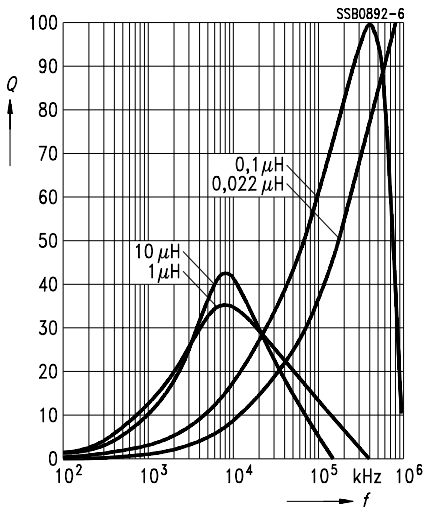

Current derating  $I_{op}/I_R$   
versus ambient temperature  $T_A$

