

NO	DESCRIPTION	MATERIAL	Q'TY	FINISH	REMARK
1	BODY 1	BRASS	1	NICKEL	B-TNC0083-N
2	BODY 2	BRASS	1	NICKEL	B-BNC0229-N
3	INSULATION	DELRIN	1	DELRIN	I-0077D
4	GASKET	SI RUBBER	1	RUBBER	RU-0010
5	WASHER	BRASS	1	NICKEL	W-0026
6	SPRING	SK-5	1	NICKEL	W-0027
7	WASHER	BRASS	1	NICKEL	W-0025
8	SLEEVE	BRASS	1	NICKEL	B-BNC0289-N
9	GASKET	SI RUBBER	1	RUBBER	RU-0019
10	WASHER	BRASS	1	NICKEL	W-0037-N
11	NUT	BRASS	1	NICKEL	N-0022-N
12	PIN	BRASS	GOLD	P-BNC0171-G	

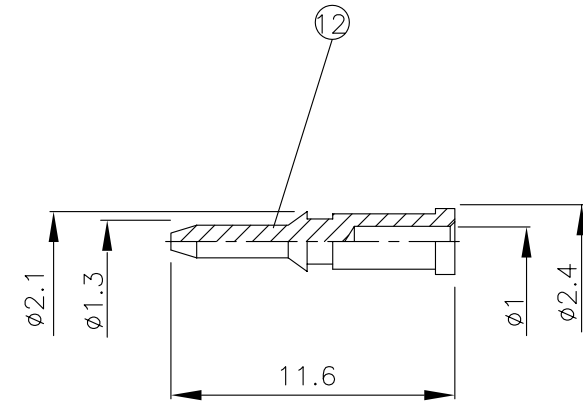
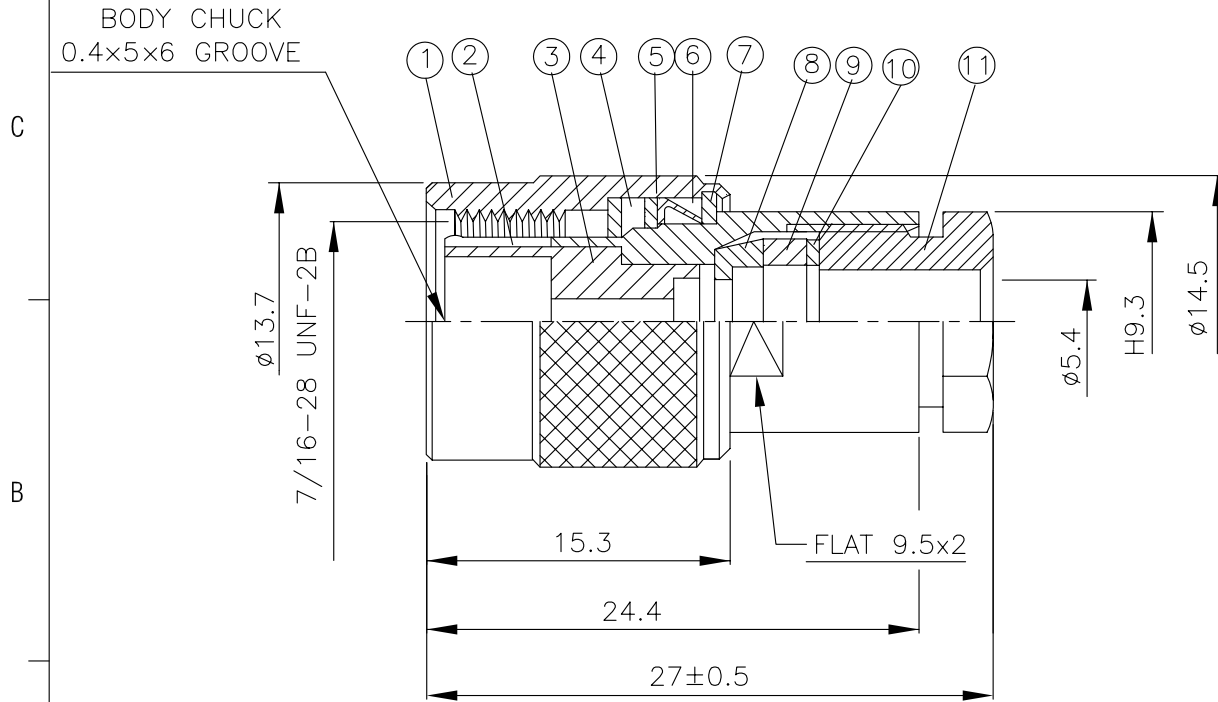
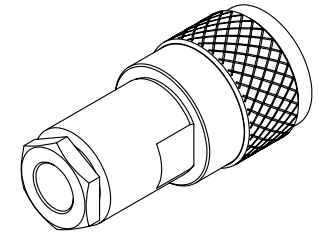

	<b>HUS-TSAN GROUP CO., LTD.</b> P.O. BOX 40-76. TAINAN. TAIWAN, R.O.C.		DRAWN MARY DATE 89.05.11	DIMENSIONS ARE IN MILLIMETERS		REVISION	
	TITLE TNC MALE CLAMP FOR RG-58U, 58A/U, 141A/U		CHECKED 黃巧君 DATE 96.01.23	UNLESS OTHERWISE SPECIFIED TOLERANCE		DESCRIPTION	ENGINEER
	PART NO. TNC-01F-DGN		Q.A. 蘇姿潔 DATE	0.5-5=±0.2	120-315=±1		
	DRAWING NO. TNC 01F DGN		APPROVAL 徐燦霖 DATE	5-30=±0.4	315-1000=±1.6		
			REVISION DATE	30-120=±0.6	1000-2000=±2.4		
			SCALE	4:1	SIZE	A	